

वर्गीय आवश्यकताएँ

सं:टीईसी/जीआर/एफए/डीएसएल-००४/०२/जनवरी-१८

(सं: जीआर/ डीएसएल-०४/०१.मार्च.२००५ को अधिक्रमित करता है)

GENERIC REQUIREMENTS

No. : TEC/GR/FA/DSL-004/02/JAN-18

(Supersedes No. GR/DSL-04/01.MAR.2005)

वेरी हाइ स्पीड डिजिटल सब्सक्राइबर लाइन(वीडीएसएल एंड वीडीएसएल2) इक्विपमेंट फॉर रिमोट ऑफिस ऍप्लिकेशन्स

VERY HIGH-SPEED DIGITAL SUBSCRIBER LINE (VDSL & VDSL2) EQUIPMENT FOR RT APPLICATIONS

© टीईसी, २०१८

© TEC, 2018

इस सर्वाधिकार सुरक्षित प्रकाशन का कोई भी हिस्सा, दूरसंचार अभियांत्रिकी केंद्र, नई दिल्ली की लिखित स्वीकृति के बिना, किसी भी रूप में या किसी भी प्रकार से जैसे - इलेक्ट्रॉनिक, मैकेनिकल, फोटोकॉपी, रिकॉर्डिंग, स्कैनिंग आदि रूप में प्रेषित, संग्रहीत या पुनरुत्पादित न किया जाए ।

All rights reserved and no part of this publication may be reproduced, stored in a retrieval system or transmitted, in any form and by any means - electronic, mechanical, photocopying, recording, scanning or otherwise, without written permission from the Telecommunication Engineering Centre, New Delhi.

दूरसंचार अभियांत्रिकी केंद्र

खुरशीदलाल भवन, जनपथ, नई दिल्ली-110001, भारत

TELECOMMUNICATION ENGINEERING CENTRE

KHURSHIDLAL BHAWAN, JANPATH, NEW DELHI-110001, INDIA

www.tec.gov.in

Release 2: January, 2018

Price: ₹ 800/-

FOREWORD

Telecommunication Engineering Centre(TEC) functions under Department of Telecommunications (DOT), Government of India. Its activities include:

- Issue of Generic Requirements (GR), Interface Requirements (IR), Service Requirements (SR) and Standards for Telecom Products and Services
- Field evaluation of products and Systems
- National Fundamental Plans
- Support to DOT on technology issues
- Testing & Certification of Telecom products

For the purpose of testing, four Regional Telecom Engineering Centers (RTECs) have been established which are located at New Delhi, Bangalore, Mumbai, and Kolkata.

ABSTRACT

This document describes the generic requirements for Very High-speed Digital Subscriber Line (VDSL) system. The GR covers the technical requirements for both Central Office equipment as well as Remote Office equipment along with requirements for copper-media characteristics for VDSL operation. This equipment shall use existing copper twisted-pairs in the PIJF cable used for phone-line in the access network of BSNL/MTNL to transport VDSL signals as per ITU-T Rec. G.993.1. The VDSL system shall be deployed in the Access networks for various high-speed applications e.g., Transparent LAN service (TLS), Video-on-Demand (VoD), Broadcast TV (BTV), Interactive Gaming, high-quality video-conferencing, medical imaging, High Speed Internet Access etc., along with voice telephony service (POTS) and ISDN-BA on the same pair.

CONTENTS

HISTORY SHEET.....	5
REFERENCE.....	6
1.0 INTRODUCTION	8
2.0 VDSL DEPLOYMENT SCENARIOS:.....	11
3.0 FUNCTIONAL REQUIREMENTS	13
4.0 POWER SUPPLY	18
5.0 PERFORMANCE REQUIREMENTS	18
6.0 TECHNICAL REQUIREMENTS OF VTU-O/VTU-R.....	19
7.0 IMPULSE NOISE IMMUNITY	20
8.0 VDSL ELEMENT MANAGEMENT SYSTEM	32
9.0 ALARMS	34
10.0 LINE QUALIFICATION	34
11.0 ENGINEERING REQUIREMENTS	35
12.0 OPERATIONAL REQUIREMENTS.....	36
13.0 QUALITY REQUIREMENTS.....	37
14.0 MAINTENANCE REQUIREMENTS	37
15.0 ACCESSORIES.....	38
16.0 DOCUMENTATION	39
17.0 PROTECTION REQUIREMENTS.....	40
18.0 OPERATING PERSONNEL SAFETY REQUIREMENTS.....	40
19.0 SECURITY AND AUTHENTICATION:.....	40
20.0 ELECTROMAGNETIC COMPATIBILITY (EMC)	41
21.0 MINIMUM EQUIPMENT FOR TESTING	46
22.0 FIELD TRIAL	46
ANNEXURE-I	47
ANNEXURE-2	51
ANNEXURE-3.....	54
ANNEXURE-4.....	56
ABBREVIATION.....	57

HISTORY SHEET

Sr. No.	Name of the Generic Requirements	No. of the Generic Requirements	Remarks
1	Generic requirements for Very High-Speed Digital Subscriber Line (VDSL) Equipment for Central office and Remote office applications	GR No.: GR/DSL-04/01.MAR.2005	First issue:
2	Generic requirements for Very High-Speed Digital Subscriber Line (VDSL) Equipment for Remote office applications	TEC/GR/FA/DSL-004/02/JAN-18	Second Issue. Includes specification for VDSL and VDSL2 RT equipment's.

REFERENCE

<u>SI No.</u>	<u>Doc Number</u>	<u>Document Name</u>
1.	ITU-T Rec. G.821	Error performance of an international digital connection operating at a bit rate below the primary rate and forming part of integrated service digital network
2.	ITU-T Rec. G.991.2	Transmission System and Media Digital System & Network for ADSL. Describes Asymmetrical subscriber Line (ADSL) Transceivers on a metallic twisted pair.
3.	ITU-T Rec. G.992.3	Transmission System and Media Digital System & Network for ADSL2 Describe Asymmetrical subscriber Line (ADSL) Transceivers on a metallic twisted pair
4.	ITU-T Rec. G.992.5	Transmission System and Media Digital System & Network for ADSL2+. Describe Asymmetrical subscriber Line (ADSL) Transceivers on a metallic twisted pair
5.	ITU-T Rec. G.994.1	Hand Shake Procedure for Digital Subscriber Line DSL Trans Receiver
6.	ITU-T Rec. G.961	Digital Transmission system on Metallic local lines for ISDN BRA
7.	RFC 2364	PPP over ATM AAL5 (PPPoA)
8.	RFC 2516	PPP over Ethernet Relay (PPPoE)
9.	RFC 1483	Bridge & Routing Mode
10.	IEEE 802.3	Institute of Electrical and Electronics Engineers (Ethernet Interface protocol)
11.	IEEE 802.1q	Institute of Electrical and Electronics Engineers (Ethernet Interface protocol) - VLAN priority protocol.

12.	IEEE 802.1p	Institute of Electrical and Electronics Engineers (Ethernet Interface protocol) - VLAN ID protocol.
13.	IS 8437	Guide on the effects of current passing through the human body
14.	IS 13252	Safety of information technology equipment including electrical business equipment
15.	IS 10437	Safety Requirements of Radio Transmitting equipment
16.	IEC Publication 61000-4-2	Testing and measurement techniques of Electrostatic discharge immunity test
17.	IEC Publication 61000-4-3	Radiated RF electromagnetic field immunity test
18.	IEC Publication 61000-4-4	Testing and measurement techniques of electrical fast transients/burst immunity test
19.	IEC Publication 61000-4-5	Test & Measurement techniques for surge immunity tests.
20.	IEC Publication 61000-4-6	Immunity to conducted disturbances
21.	QM-115	Reliability Methods & Predictions
22.	QM-118	Quality & Reliability in product design
23.	QM-205	Guidelines for standardization of workmanship for printed boards.
24.	QM-206	Guidelines for standardization of workmanship for printed boards assemblies
25.	QM-210	Guidelines for standardization of workmanship for surface mounted devices.
26.	QM-310	Transmission Equipment General Documentation.
27.	QM-333	Specification for Environmental testing of transmission equipment.

1.0 INTRODUCTION

1.1 This document describes the generic requirements for Very High-speed Digital Subscriber Line (VDSL) system(i.e. VDSL/VDSL2). The GR covers the technical requirements for Remote Office equipment (For Central Office equipment, refer GR No. TEC/GR/FA/SLM-001/01/JAN-18) along with requirements for copper-media characteristics for VDSL operation. This equipment shall use existing copper twisted-pairs in the PIJF cable used for phone-line in the access network of Telecom network to transport VDSL signals as per ITU-T Rec. G.993.1 and VDSL2 signals as per ITU-T rec G993.2. The VDSL system shall be deployed in the Access networks for various high-speed applications e.g., Transparent LAN service (TLS), Video-on-Demand (VoD), Broadcast TV (BTV), Interactive Gaming, high-quality video-conferencing, medical imaging, High Speed Internet Access etc., along with voice telephony service (POTS) and ISDN-BA on the same pair.

1.2 The VDSL system shall consist of VTU-O transmission unit (transceiver unit) installed at Central Office or street-cabinets in Fibre-to-the-Cabinet (FTTCab) deployments or in building-basement for MTU/MDU installations. The VTU-R (transceiver unit) shall be installed at customer's premises. The GR covers both point to point VDSL system as well as point to multi-point VDSL system. In point to point links, both ends of the link shall terminate on VDSL point to point modems. While in point to multi-point applications, the customer's end shall be installed with VTU-R, and the central office equipment shall be a DSLAM with VDSL PHY interfaces. Of course, in this implementation the DSLAM shall equip other PHY interfaces- viz. ADSL, SHDSL interfaces also, as per requirements. The technical and functional specifications for DSLAM requirements is covered in TEC GR No. TEC/GRFA/SLM-001/01/JAN-18.

The VDSL shall extend high bandwidths to the customers, made possible by the deep fibre-penetration closer to the end-users. The VTU-O may be combined with an Optical Network Unit (ONU) for opto-electronic conversion of VDSL signals at the network-interfaces. The ONU is out of scope for this GR. The VDSL system can be configured to run asymmetrically or symmetrically. The VDSL equipment will transmit the aggregate data-rates as per clause 7.5.3

in 0.138MHz to 12 MHz frequency band. In case of VDSL2 equipment, the availability of bandwidth up to 30 MHz allows ITU-T G.993.2 transceivers to provide reliable high data rate operation on short loops.

- 1.3 For VDSL equipment, the distance between the VTU-O (transceiver unit) and the VDSL Remote Terminal shall range from 0.3 km. to 1.5 kms. depending upon the data-rate as per clause 6.1.4 of the GR as well as the copper media characteristics. In case of VDSL2 equipment, the addition of the US0 band and means to train echo cancellers and time-domain equalizers (TEQs) allows to provide reliable operation on loops up to approximately 2.5 Kms.
- 1.4 The system shall be designed for duplex operation using Frequency Division Duplexing (FDD), separating upstream and downstream transmission between VTU-O and VTU-R. Both VTU-O and VTU-R shall provide application interfaces as well as line- interfaces as demarcated in Figure-1 of the GR. From this GR's perspective, both VTU-O and VTU-R shall be used interchangeably for all functional and technical requirements as outlined in GR. The system shall support Forward Error Correction (FEC) mechanism to provide adequate protection against impulse noise.

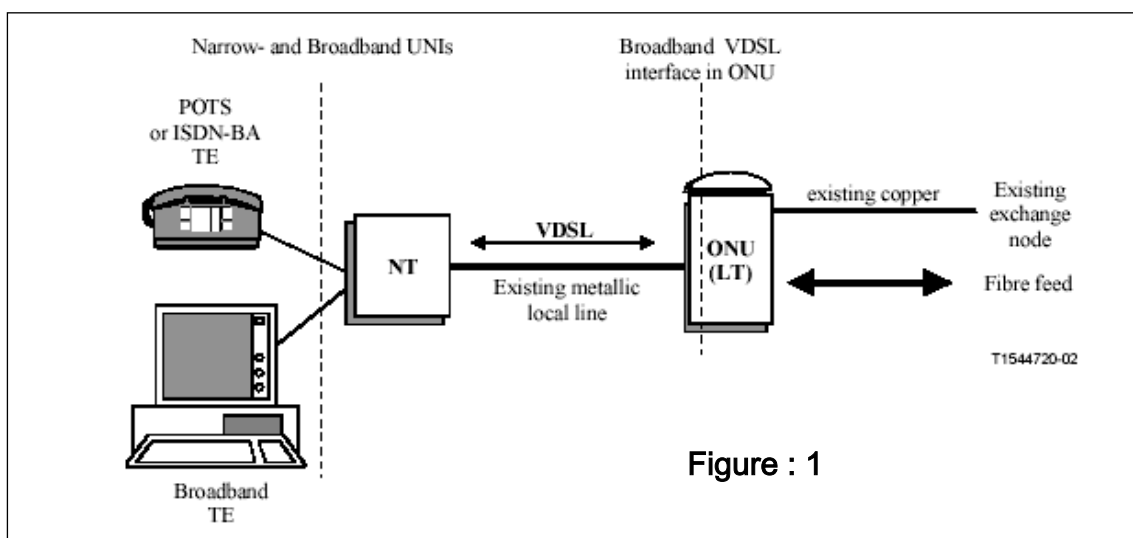

- 1.5 The VDSL equipment shall provide two data-path and four data-path options, with bit-rate under control of network operator through management system. This feature shall facilitate one or two downstream data-paths and similarly one or two data paths in the upstream directions. Dual-path (fast-channel and slow-channel) in each direction shall provide one path of each type. Latency

requirements through VDSL equipment, shall be 1 ms [worst case] as per ITU-T Rec. G.993.1. Latency requirement through VDSL2 equipment shall be as per different mode(single, dual, single latency with ROC mode) described in ITU-T Rec 993.2

- 1.6** The equipment shall facilitate remote network management through an EMS with SNMPv2c [or later version] interface towards DSLAM and CPEs, with remote software download facility and complete FCAPS implementation. The system shall facilitate auto-discovery and management of VDSL CPEs at EMS at Central Office. The management requirements are given in GR on IP-DSLAM No. TEC/FA/SLM-001/01/JAN-18. The EMS shall be scalable for a minimum of 1000 CPEs. This manufacturer shall prove this sufficiency during the testing. As regards management system scalability in terms of number of DSLAMs simultaneously managed by EMS, the purchaser shall convey exact requirements.

The system shall facilitate other management aspects by which all the specified performance, alarm and status monitoring functions, as detailed later in the GR, shall be possible. The complete database and MIBs etc., implemented in the management system shall be provided to the sufficiency as conveyed by the purchaser. Testing of MIBs compliance using management protocol analyzer shall be offered by the manufacturer.

PART II – TECHNICAL REQUIREMENTS

2.0 VDSL DEPLOYMENT SCENARIOS:

2.1 The main configurations for VDSL deployment, as envisaged in this GR, are as elaborated in Figure 2:

a) Fibre to the Exchange (FTTEx):

In FTTEx deployment, the customer premises are close to a local exchange and can be served directly from the exchange. This local exchange is generally the remote DLC node locations.

b) Fibre to the Cabinet/Curb (FTTC):

In this case, the customer premises are served from Street-Cabinets/Building basement. The VDSL VTU-O may be combined with an ONU converting the VDSL line signals in to optical signal transported across. In FTTCurb deployment, with VDSL VTU-O installed in the building basement or telephone pole around 300m away from the end-customers, VDSL transceivers shall be so designed as to operate on PSTN [Cat. 3] in-building wiring.

2.2 The VDSL equipment is expected to be deployed for point-to-point access applications requiring symmetric data needs as indicated below:

- . Delivery of leased-line services to small and medium enterprises [SME]
- . Transparent LAN Service.
- . Interactive gaming.
- . High speed data transfer.
- . Layer 2 Ethernet Private Lines.
- . Layer 2/3 VPNs etc.

Similarly, the equipment shall facilitate access applications requiring asymmetric data needs as indicated below:

- . Video-on-Demand.

- Video broadcast.
- High Speed Internet Access.

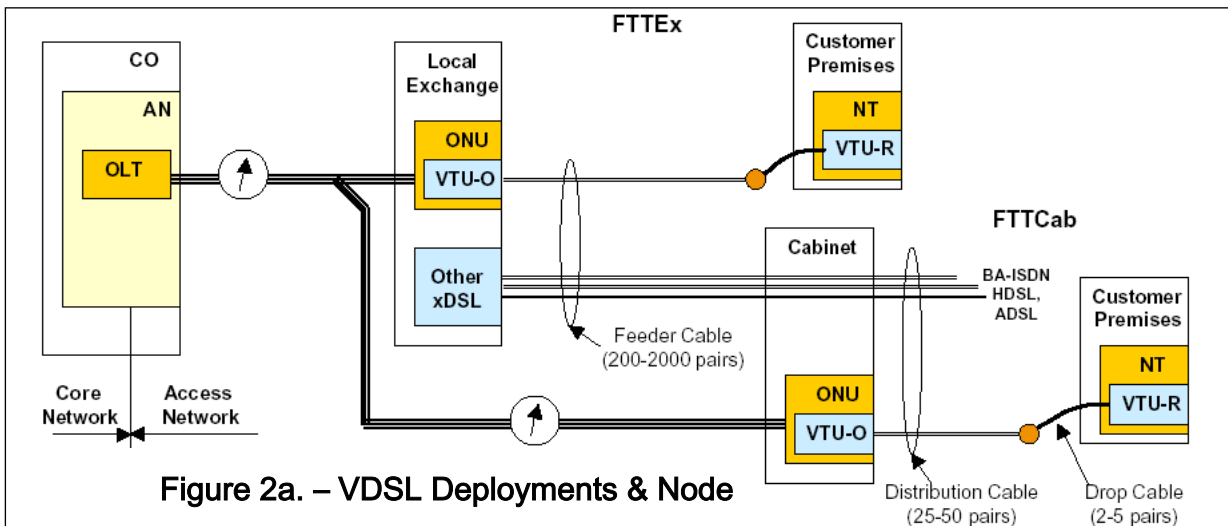
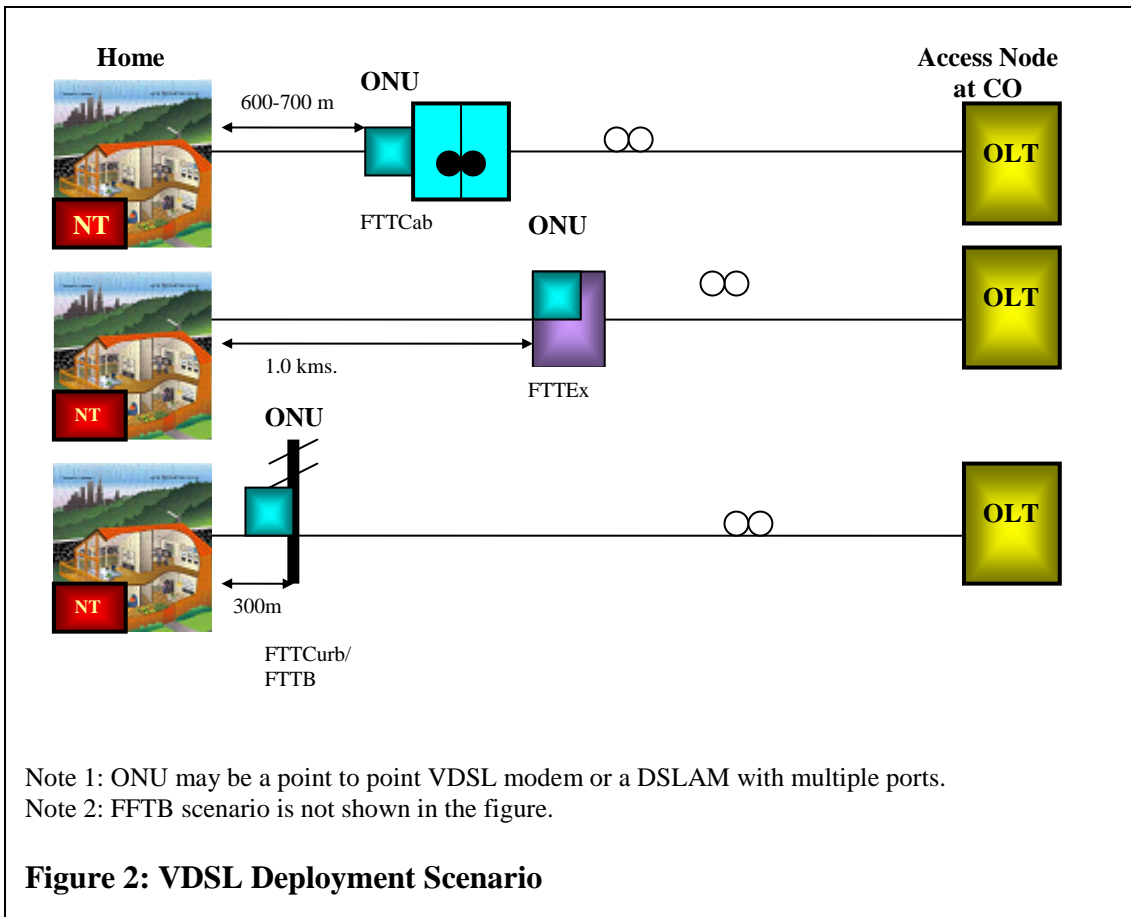

3.0 Functional Requirements

- 3.1** VDSL shall utilize frequency-division-duplexing (FDD) for upstream and downstream traffic segregation. The signals propagating to downstream & upstream directions shall use distinct frequency bands.
- 3.2** To avoid the potential problems caused by near-end cross-talk (NEXT), a fixed frequency allocation shall be adopted in VDSL system. At present four-band universal band allocation (UBA) is used by VDSL Technology as specified by ITU-T in G.993.1. For VDSL2 Technology, Band Plan: The usage of the frequency band shall comply with the band plan defined in ITU-T Rec. G.993.2 Annex A.
- 3.3** The VDSL system may implement QAM modulation or DMT modulation line code, as detailed in ITU-T Rec. G.993.1 or G.993.2. Sub-carrier spacing according to respective standards.
- 3.4** The VDSL equipment, in FTTCab & FTTEEx deployments, shall have adequate arrangements for VDSL interworking with ADSL fed through central office in the same cable-binder. The crosstalk interference in this scenario shall be in the admissible limits.
- 3.5** The functional model of a VDSL transceiver shall contain a transmission convergence (TC) sub-layer and physical-media-dependent (PMD) sub-layer. TC sub-layer shall be divided into transport-protocol specific (TPS-TC) and physical-media-specific (PMS-TC) sub-layers.
- 3.6** The TPS-TC layer shall be application specific as per equipped interface. It concerns itself largely to packaging of user data, regardless of service protocol (ATM, STM, PTM or other) and the data-rate used, into a flat data-stream to be mapped in to the PMS-TC frame. Each service protocol (i.e. ATM/STM/PTM) is supported by specific TPS-TC as defined in ITU-T G.993.1/G 993.2.
- 3.7** The VTU-R shall support Ethernet ports 10/100BaseT (auto-sensed) or USB or a combination of them, towards user, with actual nos. of ports required per VTU-R system to be specified by purchaser. Ethernet connectivity shall be implemented using RJ-45 connector on the card. The VDSL switch shall bridge

all these Ethernet flows to the VDSL line. The user service-encapsulation options are specified in clause 2.5.1.

WiFi features –VDSL modem may support single band or double band operation (2.4MHz and 5MHz) (comply with IEEE 802.11a / IEEE 802.11b / IEEE 802.11g / IEEE 802.11ac standards, as applicable.)- (If required by Purchasers).

From this GR's perspective, the VDSL VTU-R shall provide at least two 10/100BaseT or USB client ports or a combination of them. The COT-end equipment i.e. VTU-O, in point to point modem applications, shall provide 10/100BaseT and 100BaseFX @1310nm backhaul options towards broadband network. The purchaser shall communicate exact requirements.

There will be an option for dedicating the whole bandwidth on the VDSL line [applicable to both US & DS directions] to a single Ethernet port as well as to divide it out among multiple 10/100BaseT client ports under control of the management system by the user. IEEE 802.1P, 802.1Q VLAN support shall be provided on all the Ethernet ports. The details regarding VLAN administration and QoS implementation are given in Appendix I to the GR.

3.7.1 VTU-R and VTU-R shall support the following DSL encapsulation:

- a) RFC 2684 Multi-protocol over ATM Encapsulation
- b) RFC 2516 PPP over Ethernet relay (PPPoE)
- c) IPoE encapsulation with DHCP Relay and option 82 for multi-media service access
- d) RFC 1483 (bridge and routing mode).

3.8 VDSL Core Functions

The VDSL system shall be designed fully compliant to the requirements of ITU-T G.993.1/G. 993.2 and other specific requirements for Region III of the world. Some important functions are described in the GR. It does not mean that any function of ITU-T Recommendation, not described here is exempted unless specified explicitly so, in the GR. The VTU-O & VTU-R, at central office and remote end respectively, shall contain both an application invariant section and an application specific section as shown in Figure-3 as per ITU-T Rec.

G.993.1/G. 993.2. In the PMS-TC sub-layer, signals of both fast and slow path are randomized by the scrambler, protected by forward error correction (FEC) and mapped into the PMS-TC frame.

- 3.9** PMS-TC frame contains header and payload. The length of PMS-TC frame is as defined in ITU-T G.993.1/G. 993.2. The header carries frame alignment octets, network timing-reference markers, link management data and link-activation flags. Two identical fields for slow data and two identical fields for fast data share a payload. The size of both fields shall be programmable.
- 3.10** The PMD sub-layer provides encoding and modulation interfaces with the transmit media. In the PMD sub-layer the incoming PMS-TC frame is split in two streams with information data-rate ratio ($N1/N2$ are integers). Each stream, intended to be transmitted by the corresponding carrier, is encoded, modulated, and sent on the transmission media in a separate frequency band. If the first carrier can transmit all the input data, the second carrier is not used.

The main functions of the PMD layer shall be:

- Splitting the incoming PMS-TC in two data rate ratio.
- Coding & decoding.
- Modulation & demodulation
- Echo cancellation.
- Line equalization.
- Link startup.
- Time generation and recovery.

A special PMD frame is generated for each transmitted carrier to cope with propagation delay difference between two carriers introduced by the transmission media. In the receive direction, signals of both carriers are demodulated and decoded, and the received PMD frames are combined back into original PMS-TC frame format.

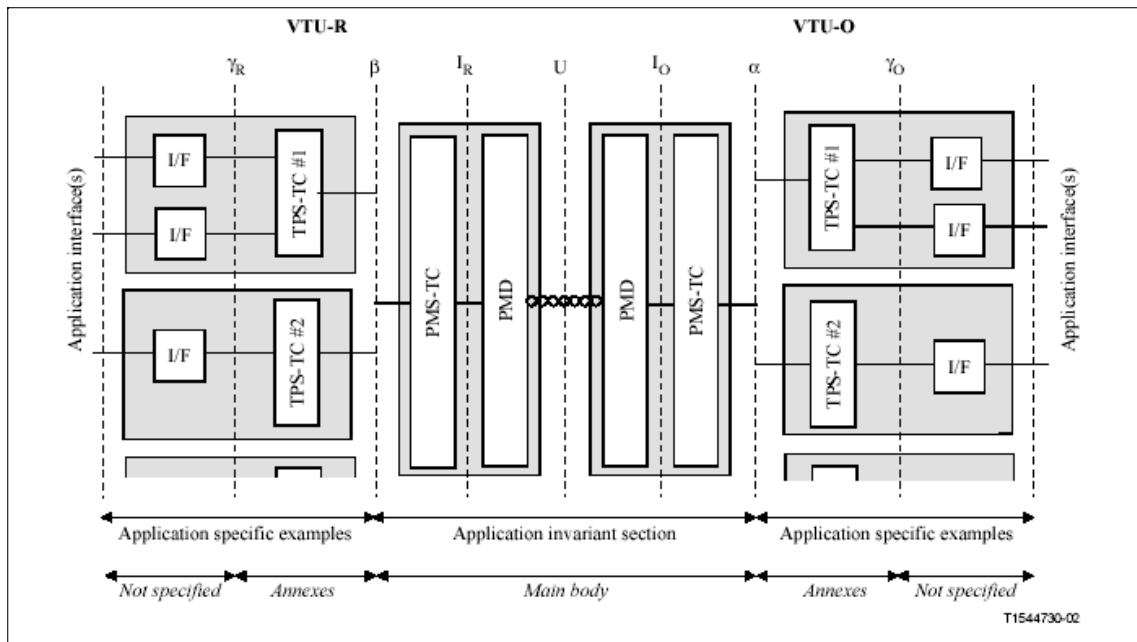

Figure 3: VTU-x Functional Reference Model

3.11 Power Back-off (UPBO)

In VDSL system, provision for power back-off shall be implemented to provide spectral compatibility between loops of different lengths. This provision shall impart the capability to VDSL transceiver operating on the same multi-pair cable to lower the transmitter power spectral density and ability to reduce its transmit PSD, whenever SNR margin at the corresponding receiver is exceeded significantly. In UPBO mode, it shall be possible for the management system to set the limiting PSD mask for the VTU-R to one of standard transmit mask. The VTU-R shall estimate the electrical length of its line, k_{lo} , and use this value to calculate the transmit PSD mask $xPSD(k_{lo}, f)$. The VTU-R shall then adapt its transmit signal to conform strictly to the mask $TxPSD(k_{lo}, f)$.

3.12 The VDSL system shall support flexible scalability for symmetric or asymmetric, field programmable bit-rates depending on the noise environment and cable-length.

3.13 VDSL Overheads

The structure of OAM entities at both VTU-O and VTU-R shall be identical. The data exchange between VTU-O and VTU-R shall be established through OAM dedicated channels as specified in ITU-T G.993.1/G.993.2.

The data rate transmitted in VDSL includes:

- (a) a VDSL embedded operation channel (EOC).
- (b) an indicator Bits (IB) channel.
- (c) a VDSL overhead control channel (VOC).

3.14 POTS splitters

The POTS splitters shall be fully compliant to ITU-T Rec. G.993.1/ G. 993.2.

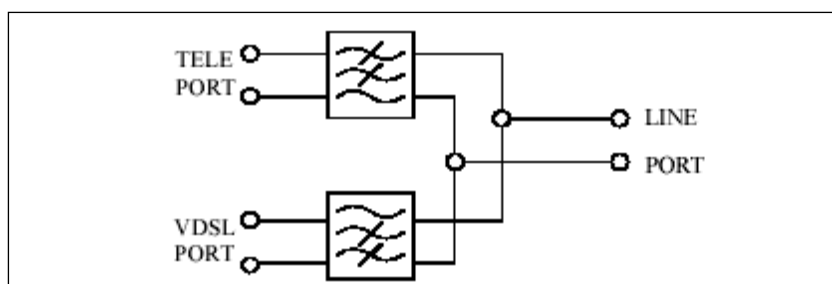

Figure 4.

- a) **The function of POTS splitter is two-fold:**
 - i) For VDSL signals, it shall provide protection from high frequency transient and impedance effects that occur during POTS operation—ringing, ring-trip and off-hook transients and impedance changes.
 - ii) For POTS voice-band service, the low pass filter (LPF) provides protection from VDSL signals which may impact through non-linear or other effects, remote devices and central office operation. This filtering shall be performed on the end-to-end voice-band connection (i.e., between POTS and PSTN interfaces).
- b) The splitter in the COT end shall be an integral part of the VTU-O equipment.
- c) The POTS splitter shall be implemented as a passive element and shall guarantee the telephone working even during the power failure at the subscriber 'premise or when the RT is switched off.

- d) The POTS splitter shall be transparent for signals within the voice-band supporting DC feed, ringing, DTMF, voice, facsimile, 16 KHz metering and also decadic-dialing.
- e) The voice frequency path shall remain active when the telephone is on-hook for the purpose of Calling Line Identification.

4.0 Power Supply

The system at 'Remote Terminal', i.e. VTU-R, shall operate on AC mains supply 230 V with variation in the range of +10% and -15% and frequency as 50 Hz \pm 2Hz.

The 'Central Office' equipment, i.e. VTU-O, shall operate on station power plant or local AC power supply and shall meet the following requirements:

- (a) Nominal power supply is -48 volts DC with a variation over the range -40 V to -60 V. The equipment shall operate over this range without any degradation in performance.
- (b) The equipment shall be adequately protected in case of voltage variation beyond the range specified in sub clause (a) and also against input reverse polarity.
- (c) The power consumption should be minimal. The actual power consumption to be furnished by the manufacturer.
- (d) The derived DC voltages in the equipment shall have protection against over voltage, short circuit and overload.

5.0 Performance Requirements

The equipment shall be tested for error performance as follows:

- **in laboratory** : BER performance over simulated hop shall be tested for less than 10^{-7} when the test noise is increased by 6 dB (this is equivalent to 6 db margin) and observed no errors for 24 hours.
- **in field** : BER performance for 48 hours shall be established to conform to ITU-T Rec. G.821 and G.826 for TDM circuits.

For Ethernet services, IETF RFC-2544 compliance shall be tested.

6.0 Technical requirements of VTU-O/VTU-R

The VDSL system shall transport various types of signals/protocols. For each application, different functional requirements shall be developed for Transport Protocol Specific-Transmission Convergence Layer (TPS-TC) which shall cover the functional requirements for transport of ATM and PTM as per ITU-T G.993.1/Para G and H or G. 993.2/ Annex L.

The VTU-O/VTU-R both shall have identical features as regards TPS-TC layer, PMS-TC and PMD layer and each layer function as mentioned in ITU-T Rec. G.993.1/ G. 993.2.

6.1 Uplink Transfer Modes at VTU-O and VTU-R

Asynchronous Transfer Mode (ATM)

As per ITU-T Rec. G.993.1/Para G and H or G. 993.2/ Annex L.

Packet Transfer Mode (PTM):

The packetized data shall be transported through VDSL system compliant to ITU-T Rec. G.993.1 (Annex-H:PTM-TC) or G. 993.2/ Annex L facilitating IP/Ethernet-based service transmission over a VDSL link. It shall extend Ethernet services from VTU-O/ONU to remote customer premises. In a point to point modem application, the system shall have two uplink interface options-

- IEEE 802.3 compliant 10/100BaseT Fast Ethernet interface
- IEEE 802.3 compliant 100BaseFX optical Fast Ethernet interface.

The uplink interface requirements for a DSLAM at central/remote office are covered under TEC GR No. TEC/GR/TX/SLM-001/01/JAN-2018. The purchaser shall convey exact requirements.

7.0 Impulse Noise Immunity

7.1 The system shall provide protection against interference from impulse noise as per ITU-T Rec. G.993.1. The system shall provide two level of protection:

- (a) In 'fast mode' for the transport of delay sensitive services such as entertainment video etc., the error shall be corrected by means of Reed-Solomon code. In high latency VDSL channel, at the maximum delay of 20ms, the error probability as per ETSI TS 101270-1 v1.2.1/para 9.1 should not be exceed when the path is subject to a noise causes burst of errors up to 500 μ s.
- (b) In 'slow mode' for transport of error sensitive services such as voice, data is first passed through interleaver before Reed-Solomon decoding, in order to spread burst of errors over several Reed-Solomon code-words. So the burst of errors is corrected at the expense of an additional delay.

7.1.1 PSD:

The power spectral density (PSD) mask inside the stop-bands shall be as per Figure 5, as given below. The narrow band-PSD mask applies between band separating frequencies- f_{tr1} and f_{tr2} . The corresponding PSD mask value inside the stop-band is detailed in Table, as below. The stop-band transmit PSD shall comply with both max. PSD limitations using measurement resolution bandwidth of 10 KHz and max. power in 1 MHz sliding-window. PSD mask shall comply Rec. ETSI TS 101270-1 V1.2.1. or annexure B of ITU-T G.993.2 and TR-115(broadband forum).

Figure 5. – Stop-band PSD mask

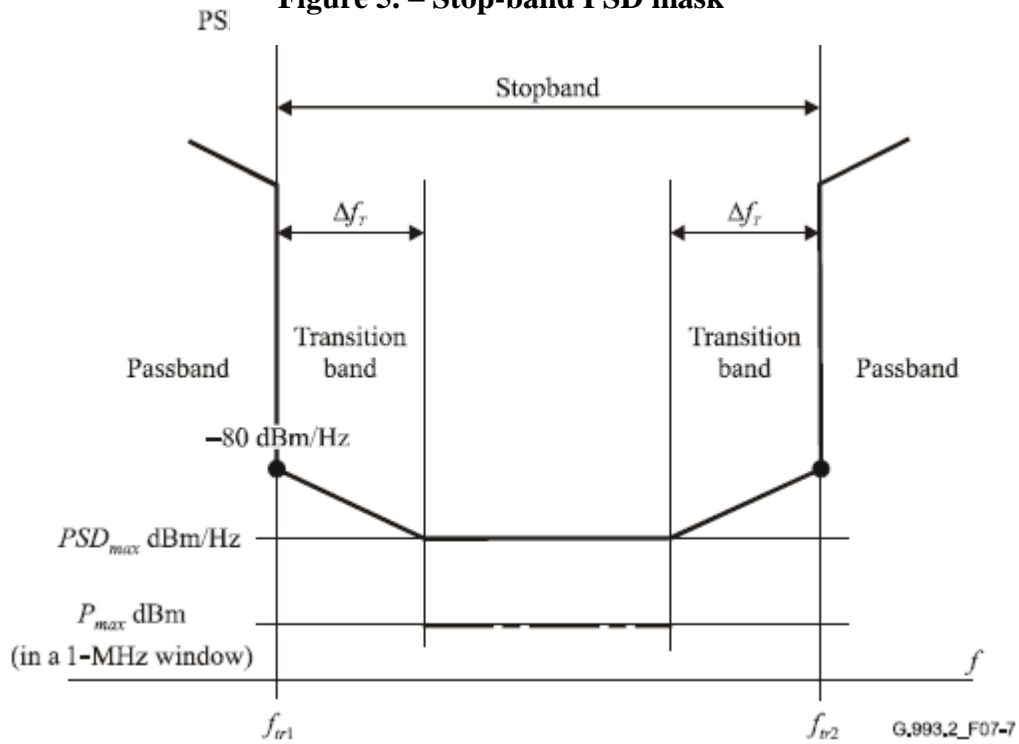

Table: G.993.1 - Stop band PSD mask

Frequency (MHz)	Limit PSD mask value (PSD _{max} dBm/Hz)	Maximum power in a 1 MHz sliding window (P _{max} dBm)
< 0.686	Subject to regional annexes	
0.686-4.0	-100	
4.0-5.0	-100	-50
5.0-30.0	-100	-52
≥ 30.0	-110	
Frequency (MHz)	Limit PSD mask value at the transition frequency (dBm/Hz)	
Transition frequency ($f = f_{tr1}$ and $f = f_{tr2}$)	-80	

7.1.2 PSD reduction function:

The system shall support the PSD reduction function in the frequency region below 1.104MHz.

7.1.3 Egress:

To reduce the effect of the radiated emission from a VDSL modem on amateur radio services, the PSD of the transmit signal within amateur-radio bands shall be able to be decreased to below -80dBm/Hz . The minimum number of notches that can be applied simultaneously in both directions shall be four and shall comply as per para 9.3.3.6.1 of Rec. ETSI TS 101270-1 V1.2.1. or Table 7.1 & 7.3 of ITU-T G.993.2.

7.1.4 Maximum distance to be covered/Electrical length requirement

The electrical length of individual test-loop is defined in terms of insertion loss at a test frequency. This frequency shall be chosen as typically high-band frequency that is used for transporting the payload bit-rate as per ETSI Part-II clause 9.2.3 and Table 7 & 8 or ITU-T G.993.2/ ETSI TS 101 271 V1.2.1.

7.2 Network Timing reference (NTR)

The system shall have a timing-reference clock of 8 KHz for end to end synchronization of transmit and receive sides. The system shall have to carry network timing reference (NTR) marker in header. The transmitters of both carriers in VTU-O shall use a transmit clock which is derived from the network clock (e.g. SDH clock, PON clock etc.) to allow end to end network synchronization. If the network work is not available, the VTU-O shall use a locally generated master clock with a maximum tolerance of ± 50 ppm to perform the link activation.

The transmitter of both carriers in the VTU-R shall use a transmit clock which is derived from the received data clock of either the first or the second downstream carrier (loop-timing). If the received data clock is lost during the steady-state transmission, the VTU-R shall use a locally generated clock with a maximum tolerance of ± 50 ppm to perform the link activation.

7.2.1 Timing and Synchronization

The VDSL system shall have to work on following reference clock depending upon the priority fixed.

- a) Internal clock
- b) Recovered clock
- c) External clock.

7.3 Frame Structure

PMS-TC frame shall be as specified in per ITU-T G.993.1/G.993.2. The header carries frame alignment octets, network timing reference markers, link management data and link activation flags. Two identical fields for 'slow data' and two identical fields for 'fast data' shall share a payload. The size of both fields shall be programmable.

7.4 Electrical Characteristics

Some of the characteristics are specified below. The rest of the characteristics shall be as per ITU-T G.993.1/G.993.2.

7.4.1 Transmitted power

The average wideband power of the transmitted VDSL power over the frequency range 10 kHz to 30 MHz shall be no greater than +11.5 dBm at the line port.

7.4.2 Impedance of Line Port

The impedance of line port shall be 135 ohms over complete VDSL frequency.

7.4.3 Return Loss

The return loss of the VDSL transceiver at line port including the high pass filter of the splitter shall be greater than or equal to 18 dB across the VDSL frequency band. If splitter is not used, return loss shall be greater than **12dB**.

7.4.4 Longitudinal Balance

All exposed port carrying VDSL signal shall be greater than 55 dB at lowest frequency and 43 dB at 30 MHz.

7.4.5 Power Spectral Density

A VDSL transceiver shall have the capability of operating to the requirements of all transmitter PSD masks as per ETSI VDSL Standard ETSI TS 101270-1 V1.2.1 - Part-I/Table 2,3,4 in Annex-1. While for VDSL2 transceiver, power spectral density is as specified in ITU-T G. 993.2.

7.5 Modulation Technique/Frequency Band Plan

VDSL shall use frequency-division-duplexing (FDD) to separate upstream and downstream transmission. The frequency plan shall consist of two upstream bands denoted as US1, US2 and two downstream bands denoted as DS1, DS2. The system shall provide distinct frequency band for upstream and downstream transmission. To avoid the potential problems caused by near-end crosstalk (NEXT), a fixed-band allocation shall be adopted in VDSL system. The system shall have to adopt four universal band allocation to reach high performance for both asymmetric and symmetric services as per ITU-T G.993.1. For VDSL2 system, modulation technique/frequency band plan is as specified in ITU-T G 993.2.

7.5.2 Standard Transmission Profiles

The standard transmission profiles are intended to provide both symmetric and asymmetric of operation (service). The main spectral plan as ETSI Standard ETSI TS 101270-1 V1.2.1 –part II/Table 7, 8, 9 and 10 in Annexure-2 shall be utilized for operation. VDSL2 profiles as specified in ITU-T Rec. G.993.2

7.5.3 Payload bit-rates

The bit rate shall be fixed for duration of service provisioned to the customer and would normally be governed by Element Manager or LCT. (ETSI Standard ETSI TS 101270-1 V1.2.1 Part-I Table-5).

Table 9: Payload bit-rates

Class (code) of operation	Downstream (kbps)	Upstream (kbps)
Class I (A4)	362 x 64 = 23 168	64 x 64 = 4 096
Class I (A3)	226 x 64 = 14 464	48 x 64 = 3 072
Class I (A2)	134 x 64 = 8 576	32 x 64 = 2 048
Class I (A1)	100 x 64 = 6 400	32 x 64 = 2 048
Class II (S5)	442 x 64 = 28 288	442 x 64 = 28 288
Class II (S4)	362 x 64 = 23 168	362 x 64 = 23 168
Class II (S3)	226 x 64 = 14 464	226 x 64 = 14 464
Class II (S2)	134 x 64 = 8 576	134 x 64 = 8 576
Class II (S1)	100 x 64 = 6 400	100 x 64 = 6 400

7.6 Technical requirements for POTS Splitters

The voice terminal shall support the following parameters-

7.6.1 Impedance:

The impedance for voice band terminal shall be 600 ohms.

7.6.2 Return loss:

The return loss of Tele-port and line-port shall be better than 18 dB from 200Hz to 4 KHz. at 135 ohms impedance as per ETSI TS101270-1V1.2.1.

7.6.3 Insertion Loss:

The Tele-port to Line-port insertion loss shall be < 0.5 db at 135 ohms impedance from 200Hz to 4KHz, the insertion loss variation (ripple) over this frequency band shall be <0.2db as per ETSI101270-1V1.2.1.

7.6.4 Isolation:

The Tele-port to VDSL-port isolation should be better than 70 dB over the bands 200Hz.

7.6.5 Signal power:

Maximum peak signal power in 200-4000Hz shall be <3dbm. Loop current shall be <63mA.

7.6.6 Ringing:

Ringing frequency shall be 25Hz.

Ringing voltage shall be 75 Vrms (nominal).

7.6.7 Unbalance about earth:

15Hz-50 Hz > 40 db terminated with 600 ohms.

50Hz- 600 Hz > 46 db terminated with 600 ohms.

600Hz-3400Hz > 52 db terminated with 600 ohms.

7.6.8 Connectors on PSTN Line:

The PSTN line shall be PIJF cable with 0.5 and 0.6 mm copper pairs. For characteristics of coppers the relevant TEC GR may be referred to.

7.6.9 The COT shall have suitable termination with connectorised cables to terminate the PSTN lines on the exchange side as well as copper-cables terminated on MDF.

7.7 VDSL Overhead Bits

7.7.1 Indicator Bits:

The indicator bits channel shall be supported by the PM-TC sub-layer. The indicator bit channel shall work unidirectional mode which requires immediate action at opposite side. The IB channel shall be independent in both & downstream directions. This channel shall carry the information in case defect/failure & path related problems.

7.7.2 VDSL Embedded Operation Channel (EOC):

The EOC shall be supported at the system (application) layer and it controls the traffic between the VTU-O and VTU-R bidirectionally. The exchanged data shall include the system related primitive performance parameters, as well as system configuration and maintenance.

7.7.3 VDSL Overhead Control (VOC) Channel:

The VOC channel shall be supported by TPS-TC sublayer - mainly a transfer VDSL link for activation and configuration between VTU-O & VTU-R.

7.8 Start-up Mechanism:

The hand-shaking procedure of VTU-O and VTU-R and detailed communication between two units shall be as laid down in ITU-T G.994.1, after power-up and before start-up of the system. The details of communication message shall be as per ITU-T G.993.1/ clause 12 and Annex I or ITU-T G.993.2/clause 12.3.2.

7.9 VDSL2 profile

The VTU-O shall support the VDSL2 profiles including 8a, 8b, 8c, 8d, 12a, 12b, 17a and 35a profiles as specified in ITU-T Rec. G.993.2

7.10 The latency path function specified in ITU-T Rec. G.993.2, including scrambling, Reed-Solomon forward error correction coding, and interleaving, shall be supported and payload transfer delay of the latency path shall be configurable by manual.

7.11 **Rate adaptation mode:** The capability for the rate adaptation modes defined in ITU-T Rec. G.993.2 and G.997.1 and TR-114(Broadband forum) shall be supported. The rate adaptation modes as follows shall be configured.

- (1). MANUAL RATE ADAPTIVE AT INIT modes,
- (2). DYNAMIC RATE ADAPTATION mode,
- (3). DYNAMIC with SOS RATE ADAPTATION mode.

7.12 The Trellis coding specified in ITU-T Rec. G.993.2 shall be supported.

7.13 On-line Reconfiguration:

- (1). The On-line Reconfiguration (OLR), including Bit Swapping, Seamless Rate Adaptation (SRA), specified in ITU-T Rec. G.993.2, shall be supported.
- (2). The OLR of SOS as specified in ITU-T Rec. G.993.2 s and G.998.4 shall be supported.
- (3). The OLR of SRA as specified in ITU-T Rec. G.998.4 shall be

supported if retransmission function is under operation.

- (4). The parameters of controlling OLR procedures as specified in ITU-T Rec. G.993.2 and G.997.1 shall be supported and configurable by manual.

- 7.14 Impulse Noise Monitoring (INM):** The impulse noise monitoring function specified in ITU-T Rec. G.993.2 shall be supported. The amount of INP that would be required to prevent data errors (INM INP Equivalent, INMINPEQ) and the time separation between impulse noise events (INM inter-arrival time, INMIAT) shall be reported. The parameters controlling INM as specified in ITU-T Rec. G.993.2 shall be supported and configurable by manual.
- 7.15 Loop Diagnostic Function:** The loop diagnostic function specified in ITU-T Rec. G.993.2 shall be supported.
- 7.16 VDSL Vectoring(optional):** Purchaser will decide about requirement of this feature.
- a) Configurable setting to realize vectoring gain during VDSL2 line initialization (including tracking during showtime) or only during showtime.
- Application: e.g. only apply vectoring during showtime to shorten initialization times.
- b) Capability to enable vectoring independently in the downstream and upstream direction on a per-line basis.
- See also ITU-T G.997.1 7.3.1.13.5 and 7.3.1.13.6.
 - Enable: crosstalk into this line is cancelled and crosstalk from this line into other lines in vectoring group can be cancelled.
 - Disable: crosstalk into this line is not cancelled but crosstalk from this line into other lines in vectoring group can be cancelled.
 - Application: e.g. only apply vectoring in downstream to shorten initialization times.
- c) Capability to flexibly configure frequency bands in which FEXT cancellation for the line is not required on a per-line basis.
- See ITU-T G.997.1 7.3.1.13.1 and 7.3.1.13.2.

- Application: e.g. do not apply vectoring in the ADSL2plus band for improved stability in presence of ADSLx lines in the same cable.
- d) Capability to configure a joining time-out, i.e. time during which the system should wait for joining lines before continuing initialization.
- e) The system shall report the FEXT coupling as a function of frequency in downstream and upstream direction as an array of complex values (XLIN) for each 'victim' line in the vectoring group. Each value in the array represents the complex FEXT coupling from a disturber line into this victim line.
 - See ITU-T G.997.1 7.5.1.38.4 and 7.5.1.38.8.
- f) The system shall report a sorted list of cancelled disturbers for each 'victim' line in the vectoring group.
 - For each disturber in the list, an indication shall be given of the crosstalk coupling strength from this disturber towards the victim line.
 - Application: As XLIN is a 3-dimensional matrix (victim line, disturber line, frequency) XLIN contains a large amount of data and the retrieval of XLIN can take considerable time. For most diagnostic applications, it is sufficient and more efficient to get a view of average coupling strength for each (victim line, disturber line) pair. This data can be displayed visually, e.g. as a heat map, and the retrieval is much quicker.
- g) The system shall report for each line in the vectoring group the modes supported by the connected VDSL2 CPE: G.vector (ITU-T G.993.5), G.vector-friendly (ITU-T G.993.2 Annex X or Y), legacy VDSL2 CPEs (ITU-T G.993.2 different from Annex X and Y).
 - Application: This data provides visibility on the vectoring support prior to vectoring activation. It can be collected network wide to give visibility on which lines still need a SW upgrade towards G.vector(-friendly).
- h) The system shall report for each line in the vectoring group the actual vectoring mode: G.vector (ITU-T G.993.5), G.vector-friendly (ITU-T G.993.2 Annex X or Y), legacy VDSL2 CPEs (ITU-T G.993.2 different from Annex X and Y).
 - See also ITU-T G.997.1 7.5.1.43.1.
- i) The system shall report for each line the number of disorderly leaving events (DLE) in the previous and current 15 minute interval and in the previous and current 24 hour interval.

- A DLE failure shall be reported when DLE events occur.
 - Application: A high number of disorderly leaving events can be an indication of a wiring issue (e.g. *poor or bad contact*) or of a CPE that is not reporting a loss of power (*LPR*) or '*dying gasp*'.
- j) The system shall report a failure in case of missing or corrupted error(f) packets.
- Application: A high number of missing or corrupted error(f) packets can be an indication of a poor quality line or a faulty CPE. Error(f) failures may prevent a correct estimation / update of the crosstalk channels.
- k) Capability to configure the CPE types that are allowed to start up on a per-line basis. Any combination of following should be configurable: G.vector CPEs (ITU-T G.993.5), G.vector-friendly CPEs (ITU-T G.993.2 Annex Y), legacy VDSL2 CPEs (ITU-T G.993.2).
- If a VDSL2 CPE is connected that does not support any of the enabled CPE modes, the DSLAM should interrupt the ITU-T G.994.1 handshake session and prevent the line starting up.
 - Application: e.g. prevent legacy lines starting up if only G.vector-friendly and G.vector CPE's are allowed.
- l) Capability to cancel crosstalk from legacy VDSL2 lines into G.vector lines, configurable on a per-line basis.
- The vendor is requested to provide a list of CPE types and CPE chipsets against which this technique has been validated.
 - The vendor should provide test results for the following two scenarios: (1) 24 legacy VDSL2 lines joining into 24 active G.vector lines; (2) 24 G.vector lines joining into 24 active legacy VDSL2 lines. For each scenario the bit rate evolution should be given of the 24 legacy VDSL2 lines and the 24 G.vector lines before joining, when the joining lines enter showtime and after 5 minutes of showtime tracking.
- m) Support of Full G.vector-friendly mode (ITU-T G.993.2 Annex Y).
- The vendor should provide test results with a mix of G.vector-friendly and G.vector lines in the same cable.
- n) Automatic fall-back to a VDSL2 spectrum with reduced bandwidth (in frequency domain) or reduced transmit PSD in case a VDSL2 CPE is connected that does not support any of the enabled CPE modes. The fall-back parameters should

- be fully configurable including but not limited to min/max bit rates in fall-back mode, VDSL2 bandwidth and PSD mask in fall-back mode.
- Application: e.g. automatically restrict the bandwidth of the VDSL2 line to the ADSL2plus band (2.2 MHz) if a legacy VDSL2 CPE is connected, in combination with reduced settings for min and max bit rates on the legacy VDSL2 line.
 - Application: e.g. automatically reduce transmit PSD of the VDSL2 line if a legacy VDSL2 CPE is connected by forcing a reduced maximum transmit PSD or capping the bit rate in combination with a configured maximum SNR margin.
- o) Automatic fall-back to a VDSL2 spectrum with reduced bandwidth (in frequency domain) or reduced PSD in case a HW failure occurs that prohibits vectoring on (a subset of) the lines in the vectoring group. The fall-back parameters should be fully configurable including but not limited to min/max bit rates in fall-back mode, VDSL2 bandwidth and PSD mask in fall-back mode.
- p) VDSL2 vectoring has to be supported according ITU-T G.993.5 in downstream and upstream direction simultaneously.
- q) Vectoring support with VDSL2 profiles 8b, 12a and 17a and capability to vector across lines with different vectoring profiles, e.g. mix of 8b and 17a.
- r) Support mechanisms to deal with disorderly leaving events (DLE), e.g. CPE power down or CPE disconnect from the line.
- Capability to shut down the downstream transmit signal after a persistent loss of upstream receive signal. The DLE timeout, i.e. the duration of persistent loss of upstream receive signal before the downstream transmit signal is muted, should be configurable.
 - The mechanism should survive micro-cuts of a few hundreds of micro-seconds, i.e. the line should stay in showtime and resume data transmission immediately after the micro-cut terminates.
- s) Support mechanisms to protect neighboring vectored lines in case a line has a bad contact (e.g. loose or intermittent wire connection), see ITU contribution 2012-11-4A-047 (November 2012 ITU meeting) .
- Application: In case of a bad contact (e.g. loose or intermittent wire connection), sometimes a line can train and reach showtime over a single wire. In many cases such lines have poor error rates. Still they offer connectivity and the end-

user may not be aware of the underlying issue, so the line may remain in service. However, such lines with a bad contact can cause a retrain of (possibly multiple) neighboring lines at the time the loose wire is reconnected (either as a permanent fix or because the intermittent contact temporarily reconnects).

8.0 VDSL Element Management System

The VDSL system shall provide local management through LCT as well as remote network management through an Element Manager [EMS]. Ethernet port shall be provided for connectivity to EMS. Similarly RS-232 or Ethernet connectivity shall be provided for LCT. Communication between the VTU-O and Customer premises unit shall be conducted via the maintenance operation channel within the VDSL shelf. The management platform shall consist of a work station having SNMPv2c [or later version] and local management shall be performed with a LCT.

The equipment shall comprise of a management system which shall monitor the performance of the VDSL segments. There shall be GUI implemented in user-friendly manner. Support for subscriber bandwidth management to limit/restrict the speed of client signals at VTU-O/VTU-R ports shall be provided. VDSL segment is characterized by a metallic transmission medium utilizing an analog coding algorithm which provides both analog and digital performance monitoring in the link. All VDSL performance monitoring data shall be transported over Embedded Operations Channel (EOC). The system shall provide management access through a standard SNMP v2c [or later version] interface with standard MIB browser. An open SNMP v23 interface or any other standard object-oriented interface viz., TMF CORBA interface shall be provided at north-bound interface of EMS for integration with other management systems. The equipment may use proprietary interface for communication between the VTU-O & VTU-R in the same system.

1. Configuration Management

It shall be possible to configure the equipment for any of the interfaces and their associated parameters as specified under for relevant interface specifications above. At least, the following shall be configured:

- Programming of a multiple interface unit.
- To create, update and retrieve the managed topology data.

- Error defects threshold.
- Enabling/ disabling of power back-off.
- SNR Margin threshold.
- VDSL version.
- Vender software version.
- Vendor ID.

2. Performance Management

It should be possible to monitor the performance status of the equipment as per ITU-T G.993.1/ G. 993.2:

- Performance history.
- Performance reporting and monitoring.
- The functionality shall store the performance data of the system.
- Power back off status.
- DC continuity status.
- Es/SES count.
- VDSL UAS count.
- VDSL CRC anomaly count.
- Status of SNR margin.

3. Fault Management

The system shall be able to report the fault events of the system as well as its interfaces. It shall provide a means to carry out the test functions as specified under for relevant interface specifications and display as:

- Alarm and status display.
- Fault localization.
- Storing and processing of current alarm information.
- Storing and processing of historical alarm information.
- Management system shall provide the on-line logging capability for historical alarm events with sufficient information such as managed resource, alarm events type, alarm severity days and time of occurrence.
- Assigning alarm severity i.e. critical, Major and Deferred.

4. Security Management

There should be provision for security management. The implementation and security framework have to be defined by the manufacturer. The supervisory and management may be a proprietary design of the manufacturer. The equipment shall support database access to management system.

- Low level protection for read only access for fault and performance information.
- Medium level protection for access to configuration status and feature.
- High level protection for control of access to aforesaid clause and to change in the configuration and control parameter.

9.0 Alarms

The following alarm shall be provisioned in VDSL system:

- (i) Derived power supply failure alarm.
- (ii) Loss of incoming signals at data interface from broad band access network.
- (iii) AIS alarm.
- (iv) Loss of synchronization.
- (v) Loss of frame alignment high bit error rate (10⁻³)
- (vi) Loss of signal from VTU-R.

10.0 Line Qualification

The copper pair shall be qualified for telephone line working from an electronic exchange as given below:

- (a) Measurement of Insulation Resistance shall be carried out. The insulation resistance values between the limbs in the pair in the cable and the limb to the earth shall not be less than 1M.ohms-km.
- (b) The foreign potential on both the limbs of DLL pair shall be less than specified values. A.C. potential across a limb and earth (a & e), b and earth (b & e) and a limb & b limb (a & b) shall be less than 6V. DC potential across 'a' limb and earth (a & e) and 'b' limb and earth (b & e) shall be less than 6V.

- (c) Measurement of impulse noise may be carried out if instrument is available. This shall be less than 80 mV.
- (d) Measurement of back ground noise may be carried out in instrument is available and shall be less than -75 dBm for the full frequency range.
- (e) Measurement of FEXT may be carried out and it shall not exceed 40 dB/km at 150 KHz.
- (f) Measurement of NEXT may be carried out and it shall not exceed 40 dB at 150 KHz.

11.0 ENGINEERING REQUIREMENTS

- 11.1** The equipment shall be fully solid state and shall adopt state of the art technology.
- 11.2** The equipment shall be compact and composite in construction and light in weight. The actual dimensions and weight the equipment shall be furnished by the manufacturers.
- 11.3** All connectors shall be reliable and of standard type approved to ensure failure free operation over long periods and under specified environmental conditions. All components shall be approved by CACT.
- 11.4** All connectors and the cable used shall be of low loss type and suitably shielded. The type of connectors used at the application interface & user interface, shall be of wire-wrapping or IDC type. All components shall be approved by CACT.
- 11.5** The equipment shall have dimensions so as to be stacked up in a standard 19" rack with front access.
- 11.6** The equipment shall have natural cooling arrangement which shall not involve any forced cooling such as by using fans etc. either inside or outside the equipment.
- 11.7** The supervisory indications, built-in test equipment (BITE), and other control switches shall be provided at convenient location on the equipment for ease of maintenance.

- 11.8** The mechanical design and construction of each card/unit shall be inherently robust and rigid under all conditions of operation, adjustment, replacement, storage and transport and shall conform to document No. SD: QM-333(ISSUE MARCH 2010)-“Standard For Environmental Testing Of Telecom Equipment”.
- 11.9** In order to avoid bending/sagging of top and base plates during the transporting, installation and maintenance process, the metal sheet used for these plates shall be minimum 1.5 mm thickness and in case of stainless steel-material, the thickness of metal sheet shall be 1mm.
- 11.10** The connectors used on the PCB and their mating connectors on the mother board shall have the tight grip to avoid jacking problems. The connectors used shall be of professional grade telecom connectors of international standards. (Euro-type or better).
- 11.11** The input/output terminations of tributary signals shall either follow extended mother board with practice using connectorised cables or directly from the mother board proper connectors at the mother-board.
- 11.12** The permanent wiring such as distribution of power supply and ground etc., shall be pre-wired.
- 11.13** Each sub-assembly shall be clearly marked with schematic reference to show its function, so that it is identifiable from the layout diagram in the handbook.
- 11.14** Each terminal block and individual tags shall be numbered suitably with clear identification code and shall correspond to the associated wiring drawings.
- 11.15** All controls, switches, indicators etc., shall be clearly marked to show their circuit diagrams and functions.

12.0 OPERATIONAL REQUIREMENTS

- 12.1** The equipment shall be designed for continuous operation.
- 12.2** The equipment shall perform satisfactorily without any degradation at an altitude up to 3000 meters above mean sea level. A test certificate from the manufacturer shall be acceptable.

12.3 The equipment shall be able to work without any degradation in saline atmosphere near coastal areas and should be protected against corrosion including vibrations.

12.4 Visual indication to show power ON/OFF status shall be provided.

12.5 Wherever the visual indications are provided, 'Green' colour for healthy and 'Red' colour unhealthy conditions would be provided. Some other colour may be used for non-urgent alarms.

13.0 Quality Requirements

13.1 The manufacturer shall furnish the MTBF/MTTR values. The calculations shall be based on the guidelines as contained in either document no.: QM-115 (January'1997)-"Reliability Methods and Predictions" or any other international standard.

13.2 The equipment shall be manufactured in accordance with international quality standards to meet the requirements of document Nos. : QM-205 and QM-206.

13.3 The equipment shall conform to the requirements for environment as specified in document No.: SD: QM-333(ISSUE MARCH 2010)-"Standard For Environmental Testing of Telecom Equipment". The applicable tests shall be taken for environmental category B2 including vibration.

14.0 MAINTENANCE REQUIREMENTS

14.1 Maintenance philosophy is to replace faulty units/sub-systems after quick on-line analysis through monitoring sockets, alarm indications and Built-in Test Equipment. The actual repair will be undertaken at centralized repair centres. The corrective measures at site shall involve replacement of faulty units/sub-systems.

14.2 The equipment shall have easy access for servicing and maintenance.

14.3 Suitable visual/audio alarms shall be provided for identification of faults in the system and faulty units.

14.4 Suitable potential-free contacts (preferably) or any other suitable method, shall be provided for extension of summary alarms.

- 14.5 As and when bugs found/determined in the software the manufacturer shall provide patches/firmware replacement, if involved, free of cost for three years. Modified documentation, wherever applicable, shall also be supplied free of cost or as mutually agreed between the vendor and the purchaser.
- 14.6 Ratings and types of fuses used are to be indicated by the supplier.
- 14.7 The manufacturer/supplier shall furnish the list of recommended spares for three years maintenance.
- 14.8 The supplier shall have maintenance/repair facility in India.
- 14.9 Supplier should guarantee the spares so long as the equipment is in service, at least for 10 years from the date of supply. The purchaser would like to stock spares as and when the supplier decides to close down the production of the offered equipment. In such an event, supplier shall give a two years notice to the purchaser so as to stock the spares.
- 14.10 To ensure multi-vendor compatibility for EMS, complete details of the network management interface & protocols shall be made available. The MIBs and other details regarding EMS etc. (as applicable), shall be supplied during TAC process.

15.0 ACCESSORIES

- 15.1 The supplier shall provide one complete set of:
- (a) All the necessary interface, connectors, connecting cables and accessories required for satisfactory and convenient operation of the equipment. Types of connectors, adopters to be used and the accessories of the approved quality shall be clearly indicated in the operating manuals which should be in conformity with the detailed list in the GR.
 - (b) Software and the arrangement to load the software at site.

Note: Additional sets may be ordered optionally.

15.2 Special tools, extender boards, extender cables and accessories essential for installation, operation and maintenance of the equipment shall be clearly indicated and supplied along with the equipment.

15.3 Special tools, extender boards, extender cables and accessories essential for repair of the equipment shall be clearly indicated and supplied in case the same are ordered.

16.0 DOCUMENTATION

Technical literature shall be user friendly & shall be in English language only with complete layout, detailed block schematic and circuit diagram of various assemblies with test voltages/waveforms at different test points of the units provided. All aspects of installation, operation, maintenance and repair shall be covered in the manuals.

The manuals shall include the following:

i) Installation, Operation and Maintenance Manual:

- a) Safety measures to be observed in handling the equipment;
- b) Precautions for installation, operation and maintenance;
- c) Test jigs and fixtures required and procedures for routine maintenance, preventive maintenance, troubleshooting and sub-assembly replacement;
- d) Illustration of internal and external mechanical parts.

ii) Repair Manual:

- a) List of replaceable parts used to include their sources and the approving authority.
- b) Detailed ordering information for all the replaceable parts shall be listed in the manual to facilitate recording of spares.
- c) Procedure for trouble-shooting and sub-assembly replacement shall be provided. Test fixture and accessories required for repair shall

also be indicated. Systematic trouble-shooting chart (fault-tree) shall be given for the probable faults with their remedial actions.

17.0 PROTECTION REQUIREMENTS

- 17.1** The equipment shall have a terminal for grounding the rack.
- 17.2** Protection against short circuit/open circuit in the accessible points shall be provided.
- 17.3** All switches/control panels shall have suitable safe-guards against accidental operations.
- 17.4** The tubes, if any, used in the equipment shall be of implosion type, and not of explosion type.
- 17.5** The equipment shall be adequately safeguarded to prevent entry of dust, insects and lizards.

18.0 OPERATING PERSONNEL SAFETY REQUIREMENTS

- 18.1** The equipment shall conform to IS 13252 part 1:(2010) “information technology Equipment Safety Part 1: General Requirements {equivalent to IEC 60950-1 (2005)} “information technology Equipment-Safety” Part 1: General Requirements and IS 10437(1986) “Safety requirements for radio transmitting equipments” equivalent to IEC 60215. The manufacturer/supplier shall submit a certificate in respect of compliance to these requirements.
- 18.2** The equipment shall follow proper construction practice to minimize unintended radiation due to leakage from any gap or monitoring points. All unused ports and monitoring points should be terminated. The power flux density shall not exceed 1mW/cm² at a distance of 2.5 cms.

Note: A test certificate from independent and accredited laboratory will be acceptable on this account.

- 19.0 Security and authentication:** It shall be possible to provide secure transport and authenticate RT i.e. VDSL modem in ACS (Authentication Configuration

Server). The RT shall comply the TR069/ITU-T Recommendations G.9980 to minimize the vulnerabilities in remote terminals i.e. VDSL Modems.

20.0 Electromagnetic Compatibility (EMC)

The equipment shall conform to the EMC requirements as per the following standards and limits indicated therein. A test certificate and test report shall be furnished from an accredited test agency.

a) Conducted and radiated emission (applicable to telecom equipment):

Name of EMC Standard: "As per CISPR 22 (2008) - Limits and methods of measurement of radio disturbance characteristics of Information Technology Equipment" for the following

Limits:-

- i. To comply with **Class B** of CISPR 22 (2008).
- ii. The values of limits shall be as per TEC Standard No. TEC/SD/DD/EMC-221/05/OCT-16.
- iii. For Radiated Emission tests, limits below 1 GHz shall be as per Table 4 (a) or 5 (a) for measuring distance of 10m **OR** Table 4 (a1) or 5 (a1) for measuring distance of 3m.

OR

Conducted and radiated emission (applicable to instruments such as power meter, frequency counter etc.):

Name of EMC Standard: "As per CISPR 11 {2015} - Industrial, scientific and medical (ISM) radio- frequency equipment -Electromagnetic disturbance characteristics- Limits and methods of measurement" for the following

Limits :-

- i. To comply with the category of Group 1 of Class B of CISPR 11 {2015}

- ii. The values of limits shall be as per clause No. 8.5.2 of TEC Standard No. TEC/SD/DD/EMC-221/05/OCT-16.

b) Immunity to Electrostatic discharge:

Name of EMC Standard: As per IEC 61000-4-2 {2008} "Testing and measurement techniques of Electrostatic discharge immunity test" for the following.

Limits: -

- i. Contact discharge level 2 { ± 4 kV} or higher voltage;
- ii. Air discharge level 3 { ± 8 kV} or higher voltage;

c) Immunity to radiated RF:

Name of EMC Standard: As per IEC 61000-4-3 (2010) "Testing and measurement techniques-Radiated RF Electromagnetic Field Immunity test" for the following

Limits:-

For Telecom Equipment and Telecom Terminal Equipment with Voice interface (s)

- i. Under Test level 2 {Test field strength of 3 V/m} for general purposes in frequency range 80 MHz to 1000 MHz and
- ii. Under test level 3 (10 V/m) for protection against digital radio telephones and other RF devices in frequency ranges 800 MHz to 960 MHz and 1.4 GHz to 6.0 GHz.

For Telecom Terminal Equipment without Voice interface (s)

Under Test level 2 {Test field strength of 3 V/m} for general purposes in frequency range 80 MHz to 1000 MHz and for protection against digital radio telephones and other RF devices in frequency ranges 800 MHz to 960 MHz and 1.4 GHz to 6.0 GHz.

d) Immunity to fast transients (burst):

Name of EMC Standard: As per IEC 61000- 4- 4 {2012) "Testing and measurement techniques of electrical fast transients / burst immunity test" for the following.

Limits:-

Test Level 2 i.e. a) 1 kV for AC/DC power lines; b) 0. 5 kV for signal / control / data / telecom lines;

e) Immunity to surges:

Name of EMC Standard: As per IEC 61000-4-5 (2014) "Testing & Measurement techniques for Surge immunity test" for the following.

Limits:-

i) For mains power input ports:

- a) 1.0 kV peak open circuit voltage for line to ground coupling
- b) 0.5 kV peak open circuit voltage for line to line coupling
- c) 4.0 kV peak open circuit voltage for line to ground coupling
- d) 2.0 kV peak open circuit voltage for line to line coupling

ii) For telecom ports:

- a) 1.0 kV peak open circuit voltage for line to ground
- b) 0.5 KV peak open circuit voltage for line to line coupling.
- c) 4.0 kV peak open circuit voltage for line to ground
- d) 2.0 KV peak open circuit voltage for line to line coupling.

f) Immunity to conducted disturbance induced by Radio frequency fields:

Name of EMC Standard: As per IEC 61000-4-6 (2013) "Testing & measurement techniques-Immunity to conducted disturbances induced by radio- frequency fields" for the following.

Limits:-

Under the test level 2 {3 V r.m.s.} in the frequency range 150 kHz-80 MHz for AC / DC lines and Signal /Control/telecom lines.

Immunity to voltage dips & short interruptions (applicable to only ac mains power input ports, if any):

Name of EMC Standard: As per IEC 61000-4-11 (2004) "Testing & measurement techniques- voltage dips, short interruptions and voltage variations immunity tests" for the following.

Limits:-

- i. a voltage dip corresponding to a reduction of the supply voltage of 30% for 500ms (i.e. 70 % supply voltage for 500ms)
- ii. a voltage dip corresponding to a reduction of the supply voltage of 60% for 200ms; (i.e. 40% supply voltage for 200ms)
- iii. a voltage interruption corresponding to a reduction of supply voltage of > 95% for 5s.
- iv. a voltage interruption corresponding to a reduction of supply voltage of >95% for 10ms.

Note 1: Classification of the equipment:

Class B: Class B is a category of apparatus which satisfies the class B disturbance limits. Class B is intended primarily for use in the domestic environment and may include:

- Equipment with no fixed place of use; for example, portable equipment powered by built in batteries;
- Telecommunication terminal equipment powered by the telecommunication networks
- Personal computers and auxiliary connected equipment.

Please note that the domestic environment is an environment where the use of broadcast radio and television receivers may be expected within a distance of 10 m of the apparatus connected.

Class A: Class A is a category of all other equipment, which satisfies the class A limits but not the class B limits.

Note 2: The test agency for EMC tests shall be an accredited agency and details of accreditation shall be submitted.

Note 3: For checking compliance with the above EMC requirements, the method of measurements shall be in accordance with TEC Standard No. TEC/SD/DD/EMC-221/05/OCT-16 and the references mentioned therein unless otherwise specified specifically. Alternatively, corresponding relevant Euro Norms of the above IEC/CISPR standards are also acceptable subject to the condition that frequency range and test level are met as per above mentioned sub clauses (a) to (g). The details of IEC/CISPR and their corresponding Euro Norms are as follows:

IEC/CISPR	Euro Norm
CISPR 11	EN 55011
CISPR 22	EN 55022
IEC 61000-4-2	EN 61000-4-2
IEC 61000-4-3	EN 61000-4-3
IEC 61000-4-4	EN 61000-4-4
IEC 61000-4-5	EN 61000-4-5
IEC 61000-4-6	EN 61000-4-6
IEC 61000-4-11	EN 61000-4-11

N.B.: The manufacturer/supplier shall submit a test certificate and test report from test agency. The test agency for EMI/EMC compliance shall be an accredited one and details of accreditation shall be submitted.

21.0 Minimum Equipment for Testing

The equipment offered for testing shall comprise VTU-O & VTU-R as per type indicated in GR with management system with servers & software. The VTU-O end equipment may also be a DSLAM. The complete technical, management, functional requirements etc., shall be as per Annexure I to the GR. The DSLAM shall be offered with an EMS and LCT during testing. The Test & Measurement instruments along with test jigs etc., shall be supplied for testing by the applicant.

22.0 Field Trial

The field trial of all types of equipment shall be conducted for a minimum of 4 weeks after successfully completion of bench and environment tests. During the field trial, the maintenance staff shall be asked to record the faults and order observation regarding the performance of the system in a special field trial Log-book.

Annexure-I

Table 2: Specification of all PSD masks for the FTTCab scenario

Frequency (kHz)	PSD line start point (dBm/Hz)	Frequency (kHz)	PSD line start point (dBm/Hz)
Pcab.#.M2		FTTCab (LT/NT) Boosted.	
1 104	-60	1 349	-51,3
1 349	-51,3	10 000	-60
10 000	-60	30 000	-60
30 000	-60	30 000	-120
Pcab.D.M1		FTTCab (LT/NT) No baseband services.	
0	-90	552	-90
552	-90	1 104	-60
1 104	-60	10 000	-60
10 000	-60	30 000	-120
Pcab.P.M1		FTTCab (LT/NT) With baseband services.	
0	-110	225	-110
225	-110	225	-90
225	-90	552	-90
552	-90	1 104	-60
1 104	-60	10 000	-60
10 000	-60	30 000	-120
<p>NOTE 1: The PSD mask for Pcab.D.M2 is identical to Pcab.D.M1 at all frequencies below 1 104 MHz. Above this frequency the PSD mask is identical to Pcab.#.M2.</p> <p>NOTE 2: The PSD mask for Pcab.P.M2 is identical to Pcab.P.M1 at all frequencies below 1 104 MHz. Above this frequency the PSD mask is identical to Pcab.#.M2.</p>			

Table 3: Specification of all PSD masks for the LT in the FTTEEx scenario

Frequency (kHz)	PSD line start point (dBm/Hz)	Frequency (kHz)	PSD line start point (dBm/Hz)
Pex.#.LT.M2 FTTEEx (LT) Boosted.			
1 104	-39,5	1 394	-51,44
1 394	-51,44	10 000	-60
10 000	-60	30 000	-60
30 000	-60	30 000	-120
Pex.D1.LT.M1 FTTEEx (LT) No baseband services present in the bundle.			
0	-39,5	1 104	-39,5
1 104	-39,5	1 677	-60
1 677	-60	10 000	-60
10 000	-60	30 000	-120
Pex.D2.LT.M1 FTTEEx (LT) No baseband service on same pair. Baseband services and ADSL over POTS present in the bundle.			
0	-60	108	-60
108	-60	138	-39,5
138	-39,5	1 104	-39,5
1 104	-39,5	1 677	-60
1 677	-60	10 000	-60
10 000	-60	30 000	-120
Pex.D3.LT.M1 FTTEEx (LT) No baseband services on same pair. Baseband services and ADSL over ISDN present in the bundle.			
0	-60	217	-60
217	-60	276	-39,5
276	-39,5	1 104	-39,5
1 104	-39,5	1 677	-60
1 677	-60	10 000	-60
10 000	-60	30 000	-120
Pex.P1.LT.M1 FTTEEx (LT) Baseband services on same pair. ADSL over ISDN present in the bundle.			

0	-90	138	-90
138	-90	138	-60
138	-60	217	-60
217	-60	276	-39,5
276	-39,5	1 104	-39,5
1 104	-39,5	1 677	-60
1 677	-60	10 000	-60
10 000	-60	30 000	-120
Pex.P2.LT.M1 FTTEEx (LT) Baseband services on same pair. ADSL over POTS present in the bundle.			
0	-90	138	-90
138	-90	138	-39,5
138	-39,5	1 104	-39,5
1 104	-39,5	1 677	-60
1 677	-60	10 000	-60
10 000	-60	30 000	-120
<p>NOTE 1: The PSD mask for Pex.D1.LT.M2 is identical to Pex.D1.LT.M1 at all frequencies below 1 104 MHz. Above this frequency the PSD mask is identical to Pex.#.LT.M2.</p> <p>NOTE 2: The PSD mask for Pex.D2.LT.M2 is identical to Pex.D2.LT.M1 at all frequencies below 1 104 MHz. Above this frequency the PSD mask is identical to Pex.#.LT.M2.</p> <p>NOTE 3: The PSD mask for Pex.D3.LT.M2 is identical to Pex.D3.LT.M1 at all frequencies below 1 104 MHz. Above this frequency the PSD mask is identical to Pex.#.LT.M2.</p> <p>NOTE 4: The PSD mask for Pex.P1.LT.M2 is identical to Pex.P1.LT.M1 at all frequencies below 1 104 MHz. Above this frequency the PSD mask is identical to Pex.#.LT.M2.</p> <p>NOTE 5: The PSD mask for Pex.P2.LT.M2 is identical to Pex.P2.LT.M1 at all frequencies below 1 104 MHz. Above this frequency the PSD mask is identical to Pex.#.LT.M2.</p>			

Table 4: Specification of all PSD masks for the NT in the FTTEEx scenario

Frequency (kHz)	PSD line start point (dBm/Hz)	Frequency (kHz)	PSD line start point (dBm/Hz)
Pcab.#.NT.M2 FTTx (NT) Boosted.			
1 104	-60	1 349	-51,3
1 349	-51,3	10 000	-60

10 000	-60	30 000	-60
30 000	-60	30 000	-120
Pex.D.NT.M1 FTTEEx (NT) No baseband services.			
0	-39,5	138	-39,5
138	-39,5	307	-90
307	-90	552	-90
552	-90	1 104	-60
1 104	-60	10 000	-60
10 000	-60	30 000	-120
Pcab.P.NT.M1 FTTEEx (NT) With baseband services.			
0	-90	552	-90
552	-90	1 104	-60
1 104	-60	10 000	-60
10 000	-60	30 000	-120
NOTE 1: The PSD mask for Pex.D.NT.M2 is identical to Pex.D.NT.M1 at all frequencies below 1 104 MHz. Above this frequency the PSD mask is identical to Pex.#.NT.M2.			
NOTE 2: The PSD mask for Pex.P.NT.M2 is identical to Pex.P.NT.M1 at all frequencies below 1 104 MHz. Above this frequency the PSD mask is identical to Pex.#.NT.M2.			

Annexure-2

Table 7: Asymmetric Profiles – Bit Rates

Carrier	Symbol Rate	Constell.	Date Rate	Total Rate		Maximum Payload Rate
	SR (Mbaud)		C	DR (Mb/s)	TR (Mb/s)	
1D	1,62(24x67,5)	32	8,1	DS	8,1	7,24
1U	1,215(18x67,5)	4	2,43	US	2,43	2,172
1D	1,62(24x67,5)	64	9,72	DS	9,72	8,688
1U	1,215(18x67,5)	4	2,43	US	2,43	2,172
1D	1,620(24x67,5)	128	11,34	DS	16,2	14,48
2D	1,215(18x67,5)	16	4,86			
1U	1,215(18x67,5)	8	3,645	US	3,642	3,258
NOTE : Payload rate is calculated assuming single latency.						

Table 8: Asymmetric Profiles – Band Allocation

Carrier	Lowest frequency	Highest frequency	Maximum PSD
	F _{LOW} (MHz)	F _{HIGH} (MHz)	
1D	0,92	2,86	-60
1U	3,12	4,58	
1D	0,92	2,86	
1U	3,12	4,58	
1D	0,92	2,86	
2D	5,55	7,01	
1U	3,12	4,58	

Table 9: Asymmetric Profiles – Bit Rates

Carrier	Symbol Rate	Constell. C	Date Rate	Total Rate		Maximum Payload Rate (Mb/s)
	SR (Mbaud)		DR (Mb/s)	TR (Mb/s)		
1D	1,62(24x67,5)	32	8,1	DS	8,1	7,24
1U	1,62(24x67,5)	16	6,48	US	8,1	7,24
2U	0,81(12x67,5)	4	1,62			
1D	1,62(24x67,5)	64	9,72	DS	9,72	8,688
1U	1,62(24x67,5)	16	6,48	US	9,72	8,688
2U	1,62(24x67,5)	4	3,24			
1D	1,62(24x67,5)	128	11,34	DS	16,2	14,48
2D	1,215(18x67,5)	16	4,86			
1U	1,62(24x67,5)	32	8,1	US	1,62	14,48
2U	2,7(24x40,5)	8	8,1			
NOTE: Payload rate is calculated assuming single latency.						

Table 10: Asymmetric Profiles – Band Allocation

Carrier	Lowest frequency	Highest frequency	Maximum PSD (dBb/Hz)
	F _{LOW} (MHz)	F _{HIGH} (MHz)	
1D	0,92	2,86	-60
1U	3,15	5,09	
2U	7,88	8,57	
1D	0,92	2,86	
1U	3,15	5,09	
2U	7,87	9,81	
1D	0,92	2,86	

2D	5,55	7,01	
1U	3,15	5,09	
2U	7,9	11,14	

Annexure-3

Band plan A

TableA-1/G.G.993.1- Bandplan A

	MHz	Direction
F0-f1	0.025-0.138	Usage and Directional are optional
F1--f2	0.138-3.75	Downstream
F2-f3	3.75-5.2	Upstream
F3-f4	52-8.5	Downstream
F4-f5	8.5-12	Upstream

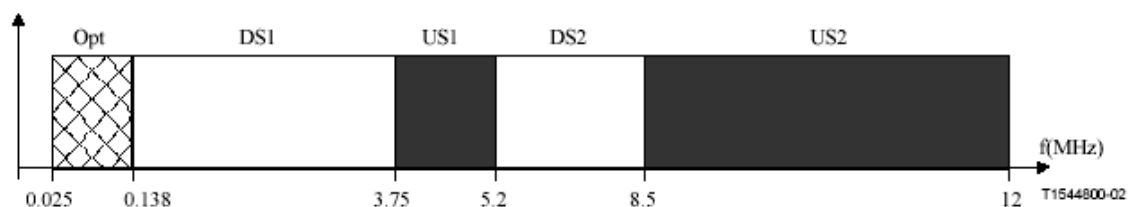
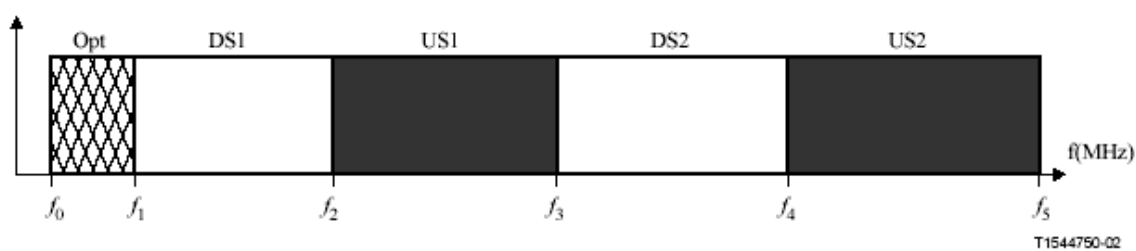

Figure A-1/ G.993.1-Bandplan A

Bandplan B

	MHz	Direction
f0-f1	0.0.25-0.138	Usage and Directional are optional
f1--f2	0.138-3.0	Downstream
f2-f3	3.0-5.1	Upstream
f3-f4	5.1-7.05	Downstream
f4-f5	7.05-12	Upstream

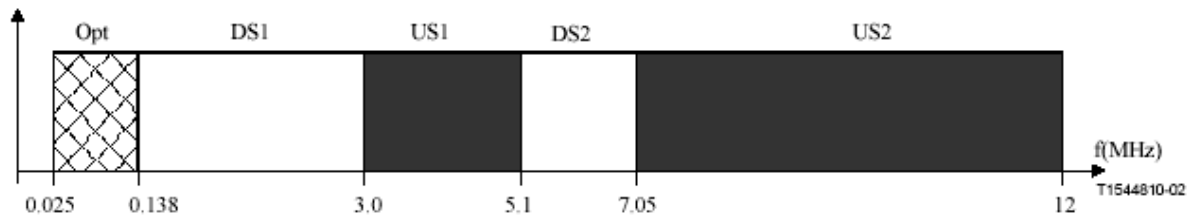

Figure B-1/ G.993.1-Bandplan B

Bandplan C

	MHz	Direction
f0-f1	0.0.25-0.138	Usage and Directional are optional
f1--f2	0.138-3.0	Downstream
f2-f3	2.5-3.75	Upstream
f3-f4	3.75-Fx	Downstream
f4-f5	Fx-12	Upstream



Figure C-1/ G.993.1-Bandplan C

Note: All the above bandplans shall be configurable per VDSL port at VTU-O and VTU-R through management system.

Annexure - 4

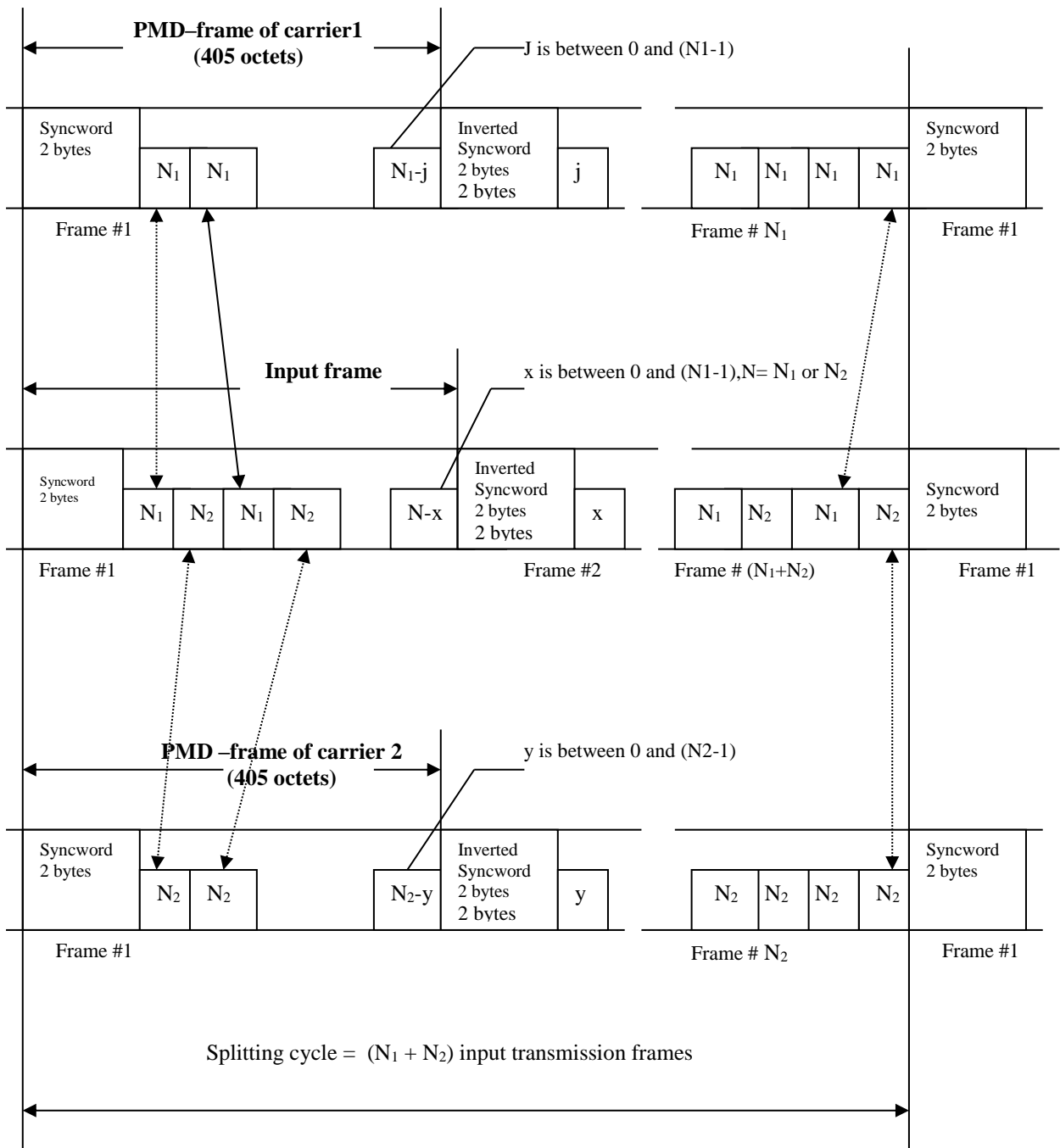

Figure – 4: PMD-frame Format

Abbreviation

ADSL	:	Asymmetric Digital Subscriber Line
ATM	:	Asynchronous Transfer Mode
BA-ISDN	:	Basic-rate Access Integrated Service Digital Network
BER	:	Bit Error Ratio
BITE	:	Built-in Test Equipment
BSNL-QA	:	Bharat Sanchar Nigam Limited Quality Assurance
BTv	:	Broadband TV
CACT	:	Component Approval Center of Telecommunication
COT	:	Central Office Terminal
CPE	:	Customer Premises Equipment
CRC	:	Cyclic Redundancy Check
DC	:	Direct Current
DS	:	Down-Stream
DTMF	:	Dual Tone Multi Frequency
EMC	:	Electro Magnetic Compability
ES	:	Errored Second
ETSI	:	European Standard of Telcom. Institute
FDD	:	Frequency Division Duplexing
FEC	:	Forward Error Correction
FTT cab	:	Fiber To The Cabinet/Curb

FTTEx	:	Fiber To The Exchange
HDSL	:	High-bit-rate Digital Line
HFTP	:	Hybrid Fiber Twisted Pair
IB	:	Identification Bit
ISDN	:	Integrated Service Digital Network
ITU-T	:	International Telecommunication Union - Telecommunication Standard Sector
LAN		Local area network
LPF	:	Low Pass Filter
Mhz	:	Mega Hertz
MIB	:	Management information base
MTBF	:	Mean Time Between Failure
MTTR	:	Mean Time to Restore
NEXT	:	Near End Cross Talk
NMS	:	Network Management System
NNMS	:	National Network Management System
NTR	:	Network Timing Reference
OAM	:	Operation, Administration & Maintenance
OLT	:	Optical Line Terminal
ONU	:	Optical Network Unit
PCB	:	Printed Card Board
PON	:	Passive Optical Network

POT	:	Plain Old Telephone
PMD	:	Physical Media Dependent
PMS-TC	:	Physical Media-Specific TC Layer
PSD	:	Power Spectral Density
PSTN	:	Public Switch Telephone Network
PTM	:	Packet Transfer Mode
ROC		Robust Overhead Channel
RF	:	Radio Frequency
RNMS	:	Regional Network Management System
SDH	:	Synchronous Digital Hierarchy
SES	:	Severely Errored Second
SNMP	:	Simple Network Management Protocol
SNR	:	Signal-to-Noise Ratio
TLS	:	Transport LAN service.
TC	:	Transmission Convergence Layer
TPS-TC	:	Transmission Protocol Specific TC Layer
TMN	:	Telecommunication Management Network
UAS	:	Unavailable Second
UBA	:	Universal Band Allocation
UPBO	:	Upstream Power Back Off
US	:	Unavailable Second
VDSL	:	Very High-speed Data Subscriber Line

VDSL-NT : Very High-speed Data Subscriber Line - Network
Terminal

VoD video on demand

VTU-O : VDSL Transceiver Unit at ONU/ Central Office

VTU-R : VDSL Transceiver Unit at Remote Office

-----*END OF DOCUMENT*-----