



सत्यमेव जयते
Government Of India

टीईसी 49189:2022

TEC 49189:2022

**दूरसंचार विभाग के लाइसेंस प्राप्त सेवा प्रदाताओं को
भारतीय मानक समय के वितरण के लिए राष्ट्रीय योजना**

**National Plan for Distribution of Indian Standard Time
to Licensed Service Providers of Department of
Telecommunications**



ISO 9001:2015

**दूरसंचार अभियांत्रिकी केंद्र
खुर्शीद लाल भवन, जनपथ, नई दिल्ली-110001, भारत
TELECOMMUNICATION ENGINEERING CENTRE
KHURSHID LAL BHAWAN, JANPATH, NEW DELHI-110001, INDIA
www.tec.gov.in**

इस सर्वाधिकार सुरक्षित प्रकाशन का कोई भी हिस्सा, दूरसंचार अभियांत्रिकी केंद्र, नई दिल्ली की लिखित स्वीकृति के बिना, किसी भी रूप में या किसी भी प्रकार से जैसे - इलेक्ट्रॉनिक, मैकेनिकल, फोटोकॉपी, रिकॉर्डिंग, स्कैनिंग आदि रूप में प्रेषित, संग्रहीत या पुनरुत्पादित न किया जाए ।

All rights reserved and no part of this publication may be reproduced, stored in a retrieval system or transmitted, in any form and by any means - electronic, mechanical, photocopying, recording, scanning or otherwise, without written permission from the Telecommunication Engineering Centre, New Delhi.

© टीईसी, 2022

© TEC, 2022

Release 1: AUG, 2022

FOREWORD

Telecommunication Engineering Centre (TEC) is the technical arm of Department of Telecommunications (DOT), Ministry of Communications, Government of India.

Its activities include:

- Framing of TEC Standards for Generic Requirements for a Product/Equipment, Standards for Interface Requirements for a Product/Equipment, Standards for Service Requirements & Standard document of TEC for Telecom Products and Services
- Formulation of Essential Requirements (ERs) under Mandatory Testing and Certification of Telecom Equipment (MTCTE)
- Field evaluation of products and Systems
- Designation of Conformity Assessment Bodies (CABs)/Testing facilities
- Testing & Certification of Telecom products
- Adoption of Standards
- Support to DOT on technical/technology issues

For the purpose of testing, four Regional Telecom Engineering Centres (RTECs) have been established which are located at New Delhi, Bangalore, Mumbai, and Kolkata.

ABSTRACT

As per the licensing conditions, LSPs are obliged to have a traceability facility to uniquely identify the users at any point in time. In order to do so, all network elements of all LSPs in the telecom infrastructure must trace back to a single timing source.

This document is a plan for distributing Indian Standard Time to Licensed Service Providers in the Indian Telecom Network.

Contents

FOREWORD	3
ABSTRACT	4
HISTORY SHEET	7
REFERENCES	8
1. Introduction	9
2. Time Reference in Telecom Network and Services	10
A. Time Reference	10
B. Indian Standard Time (IST)	10
C. Tracing Requirement for Licensed Service Providers	11
D. Time Synchronization Requirements of Telecommunication Systems	12
I. Significance in Telecom Services	12
II. Significance in National Security	14
3. Architecture for Distribution of Time Reference Signal	15
A. Setting up of Time Source Centres	15
B. Dissemination of Time Reference from CSIR-NPL to TSCs	20
I. Two-way Satellite Time and Frequency Transfer (TWSTFT):	20
II. Carrying UTC(NPLI) through Optical Connectivity:	21
III. Common View of Global Navigational Satellite System (CVGNSS)	23
IV. Using Indian Navigational Satellite System (NavIC)	24
C. Management of TSCs	25
D. Distribution of Time Reference Signal from TSC to LSP	26
I. Distribution of Time Reference Signal Using PTP protocol	26
II. Distribution of Time Reference Signal Using NTP protocol	27
III. Accessing Indian Standard Time Reference Signal through NavIC	30
IV. Distribution of Time Reference Signal Using Using E1 interface	31

V.	Distribution of Time Reference Signal Using SyncE	32
4.	Deployment Plan	33
A.	General Guidelines	33
B.	Security and Reliability Guidelines	35
C.	Trial Phase and Proof of Concept	36
D.	First phase of Implementation	37
E.	Final Phase of Implementation	39
F.	Constitution of Deployment Committee	40
	Abbreviations	41

HISTORY SHEET

S. No.	Name of the document and Number	Issue	Remarks
1.	National Plan for Distribution of Indian Standard Time to Licensed Service Providers of Department of Telecommunications.	01	Issued in August 2022
2.			

REFERENCES

The following Standards are referred to in this document. These standards are subject to revision. It is encouraged to apply the updated version.

- i. Precision Time Protocol (PTP) Grandmaster Clock - GR (TEC 49170:2020)
- ii. Precision Time Protocol (PTP) Slave Clock - GR (TEC 49070:2012)
- iii. Network Timing Protocol Server - GR (TEC 48150:2019)
- iv. Time Synchronization in IP Networks - SR (TEC 49004:2019)
- v. Primary Reference Clock- GR (TEC 49150:2019)
- vi. Element Management Systems [eMS]- Standard - (TEC 52006:2016)
- vii. LAN Switch - GR (TEC 48060:2014)
- viii. Router - GR (TEC 48050:2022)

1. Introduction

The Department of Telecommunications issues licenses to telecom service providers for providing various telecom services. Licensed service providers (LSPs) set up their own telecom network to provide telecom services as per the terms and conditions of the license. Licensed service providers (LSP) are obliged to provide facilities to trace all users. Having a standard time reference is critical for the traceability of the users.

Telecom Network is a critical infrastructure of the nation. It is very important that all licensed Service providers use reliable authorized time references for their operation.

National Physical Laboratory provides an authorized source of Time through UTC(NPLI).

Global Navigation Satellite Systems (GNSS) is also another source of time reference through PNT Service. NavIC through Positioning Navigation and Timing (PNT) service is providing time references that can be traced back to UTC(NPLI).

The dependence of telecommunications services on Global Navigation Satellite Systems (GNSS) for time reference signals is vulnerable to disruption. The availability of accurate time reference signals from a robust national timing infrastructure is required to complement PNT time reference and mitigate the impact of any disruption to GNSS signals to these critical services.

This plan proposes setting up Time Source Centres (TSC) to develop a robust, geographically distributed time reference infrastructure across India. The aim is to standardise time reference in Licensed Telecom networks to improve security and resilience.

This document details the authorized time reference sources and the required network infrastructure for its distribution to Licensed Service Providers (LSPs) of the Department of Telecommunications.

2. Time Reference in Telecom Network and Services

A. Time Reference

Time Reference for synchronization mainly comprises frequency, phase and time (TOD) reference. The state in which the clock frequencies of different systems match is called frequency synchronization and the state in which the timings between the clocks agree is called phase synchronization. In particular, when the clock timing is synchronized with Coordinated Universal Time (UTC), that state is defined as time synchronization.

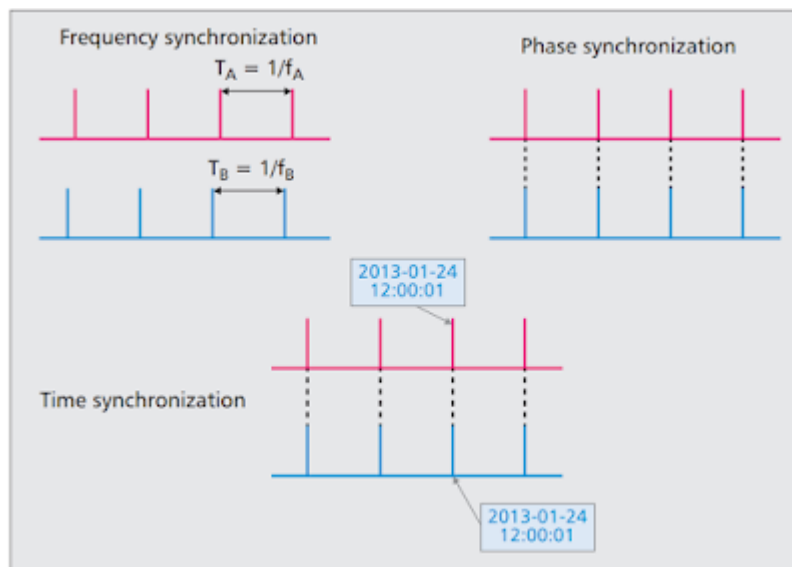

B. Indian Standard Time (IST)

Council for Scientific and Industrial Research - National Physical Laboratory (CSIR-NPL) is also known as “the time-keeper of the nation”. CSIR-NPL is responsible for the maintenance and dissemination of Indian Standard Time and for keeping it traceable to the Coordinated Universal Time (UTC) provided by the International Bureau of Weights and Measures (BIPM) located in Sevres, France.

CSIR-NPL has a “Primary Timescale” generating UTC(NPLI) which is the realization of UTC at NPLI. The IST (i.e. UTC(NPLI) plus 5:30 hours), which is generated using a bank of caesium clocks and hydrogen masers, has current systematic uncertainty of a few nano-seconds with respect to UTC.

CSIR-NPL provides Indian Standard Time to users via different techniques using terrestrial and satellite links.

IST is also disseminated by NavIC using PNT services. It is operated by the ISRO, Government of India. NavIC system time is steered to IST maintained by NPL.

C. Tracing Requirement for Licensed Service Providers

1. Unified License issued by the Department of Telecommunications covers the following services:

- i. Unified License (All Services)
- ii. Access Service (Service Area-wise)
- iii. Internet Service (Category-A with All India jurisdiction)
- iv. Internet Service (Category-B with jurisdiction in a Service Area)
- v. Internet Service (Category-C with jurisdiction in a Secondary Switching Area)
- vi. National Long Distance (NLD) Service
- vii. International Long Distance (ILD) Service
- viii. Global Mobile Personal Communication by Satellite (GMPCS) Service
- ix. Public Mobile Radio Trunking Service (PMRTS) Service
- x. Very Small Aperture Terminal (VSAT) Closed User Group (CUG) Service
- xi. INSAT MSS-Reporting (MSS-R) Service
- xii. Resale of International Private Leased Circuit (IPLC) Service

2. The licensed service providers have been given licenses to operate data services as per the Indian Telegraph Act. As per the relevant clauses of their license conditions clauses, the licensees have to abide by the following: -

i. Clause 38.2 of Unified License is reproduced as follows:-

“The licensee is obliged to provide, without any delay, all the tracing facilities to trace nuisance, obnoxious or malicious calls, messages or communications transported through his equipment and network, to the agencies of Government of India as authorised from time to time, when such information is required for investigations or detection of crimes and in the interest of national security. Any damages arising on the account of Licensee’s failure in this regard shall be payable by Licensee.”

- ii. Each licensed service provider(LSP) must maintain a log of all users connected and the service they are using (mail, telnet, http etc.). The LSPs must also log every outward login or telnet through their computers. Type of logins, where the identity of the logged-in user is not known, should not be permitted.
3. In view of the above, it is crucial for the LSPs to ensure that proper mechanisms are in place to uniquely identify the users at any point of time. However, it is observed that security agencies are having difficulties in the identification of subscribers at any given point of time according to the information provided by the service providers.
4. In this regard, it is indicated that one essential requirement is that all service providers implement a uniform IST time zone time synchronization as part of the solution to address the problem of traceability of users.

D. Time Synchronization Requirements of Telecommunication Systems

I. Significance in Telecom Services

Accurate and reliable time is needed to determine when an event occurs, in what order a particular sequence of events occurs, or when to schedule an event that is to occur at a particular time in the future.

Many services — like IPTV, VoIP, wireless content downloads and multi-player gaming — involve real-time delivery of multimedia. Not only do these services require more accurate time than networks previously needed to provide, they but they also need time delivered in more places and more often. Real-time services with high QoS expectations require real-time monitoring and measurements at many points in the network — not just at a few as in the past — right to the customer premise and end-user device. Moreover, these services typically employ multiple systems to complete service requests, leading to an explosion in the number of systems that need time synchronization.

Many other packet-based services — in addition to IPTV and VoIP — also require accurate, secure, reliable, and network-wide time synchronization.

Time synchronization also has an impact on network operations itself for example in

- Network Operation
- Performance monitoring and measurements
- Network fault diagnostics and recovery
- Billing and CDR generation

Requirements of Time Synchronization in various Telecom Technologies

Application	Precision Needed
Wired (sources of timing)	
ePRTC (enhanced primary reference time clock)	± 30 ns with respect to Coordinated Universal Time (UTC).
PRTC (primary reference time clock)	± 100 ns with respect to UTC
Wireless	
5G wireless communication	± 65 to 240 ns
CDMA2000	± 3 to 10 μ s
TD-SCDMA	± 3 μ s
WCDMA-TDD (Node TDD mode)	± 2.5 μ s
W-CDMA MBSFN	± 12.8 μ s
LTE MBSFN	$< \pm 1$ μ s (spec. still under study)
W-CDMA (Home Node TDD mode)	Microsecond-level accuracy
WiMAX	± 1 – 1.43 μ s

LTE-TDD (wide area base station)	3 μ s (small cell, <3 km radius)
	10 μ s (large cell, >3 km radius)
LTE-TDD (home area base station)	3 μ s (small cell, <500 m radius)
LTE-TDD to CDMA handovers	\pm 10 μ s
IP network delay monitoring	\pm 100 μ s to \pm 1 ms

II. Significance in National Security

Telecom Network is a critical infrastructure of the nation. Security and stability of the nation are also significantly dependent on the health of telecom infrastructure. Time reference is a kind of Achilles' heel for telecom networks, it may cause disruption of telecom services. It is in our national interest that all network elements remain in sync with the time reference managed and supplied through authorized sources. The authorized time distribution centres would give the confidence to withstand the cyber-attacks from the adversaries.

Setting up of terrestrial time distribution network would augment to the strength of the nation to suitably mitigate cyber-attacks on GNSS time reference. It would be commensurate with the nation's status as a world leader in technology.

Time reference also plays a critical role in uniquely identifying the users that may be necessary for national security. Mandate to use of Indian Standard Time as a time reference in all Network elements of all Licensed Service providers would resolve the issues pertaining to the identification of IP packets originating in the network elements having different time references.

3. Architecture for Distribution of Time Reference Signal

CSIR-NPL is the official timekeeper of the country. It provides the time reference which is Indian Standard Time(UTC(NPLI)). Time Source Centres(TSCs) are to be set up for terrestrial distribution of time reference signals to LSPs. TSC would provide the Time reference signal, which can be traced back to UTC(NPLI), to LSPs on various protocols and interfaces. These TSCs would be maintained by Department of Telecommunications.

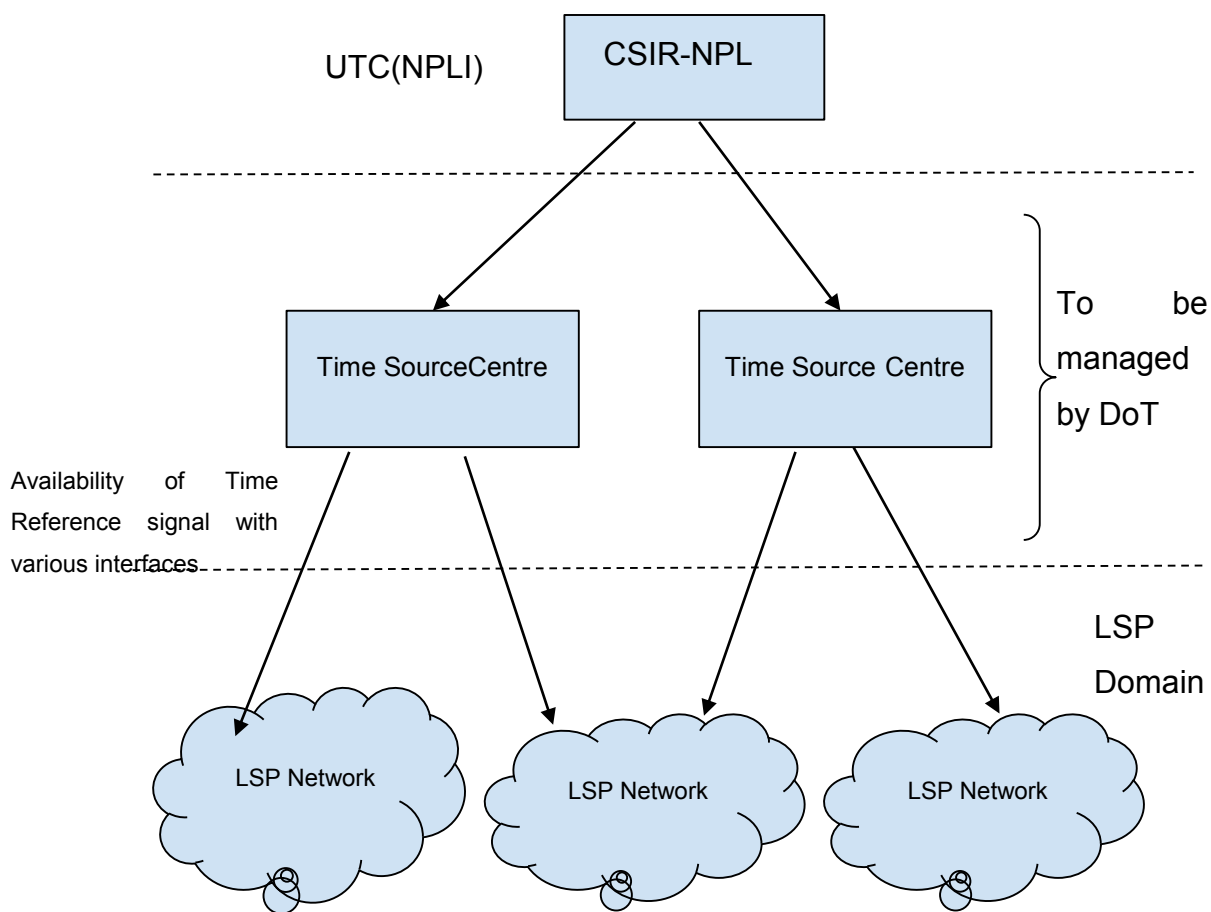

A. Setting up of Time Source Centres

Time Source Centres are to be set up. It will use Time reference from CSIR-NPL to sync its clock and provide the Time reference signal traced back to UTC(NPLI) on various protocols and interfaces to Licensed Service Providers(LSPs). It will be spread over the territorial geography of India as per the deployment plan.

Time Source Centre

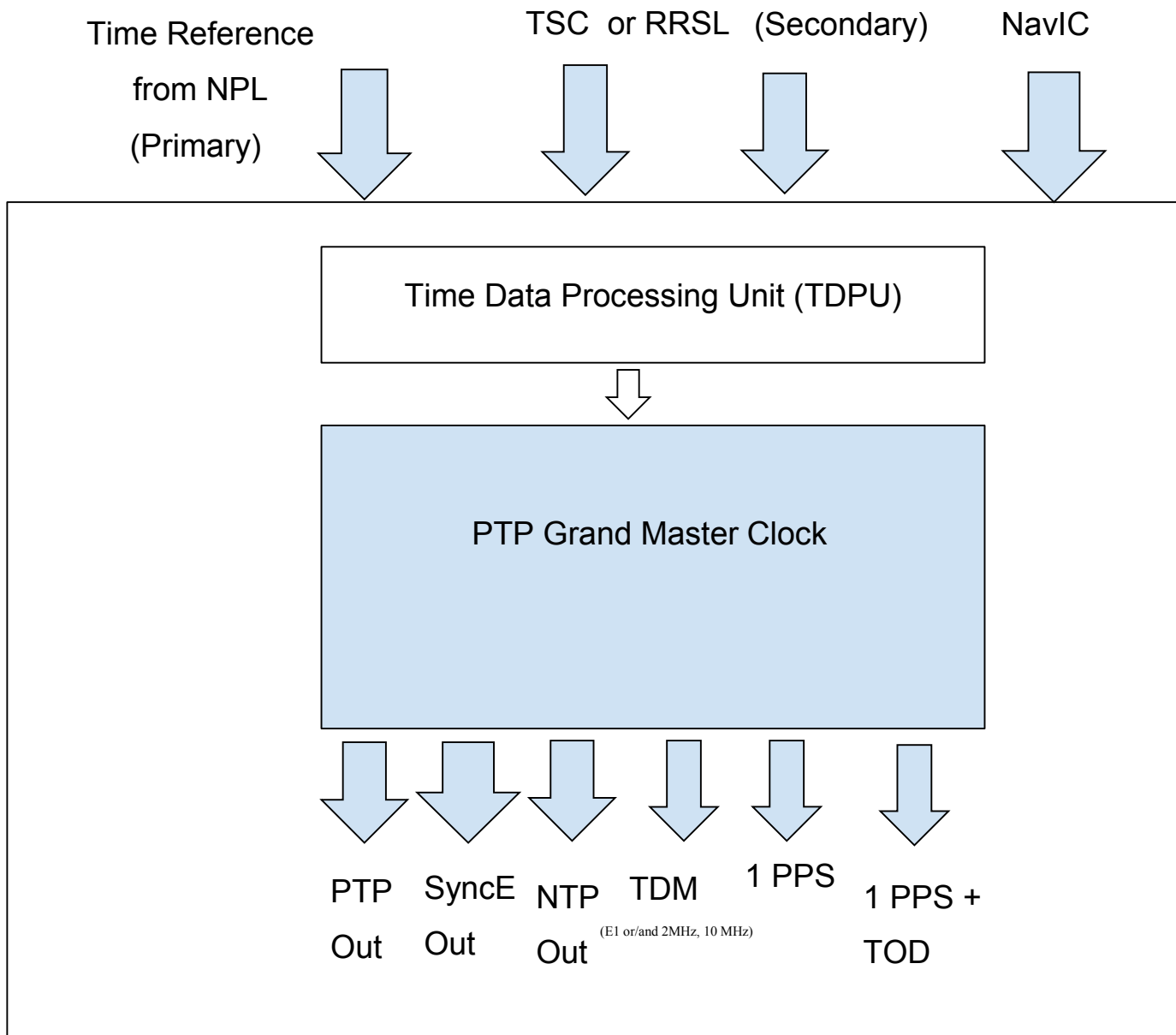

- i. Time Source Centres would host Precision Time Protocol Grand Master (PTP GM) Clock as per - GR (TEC 49170:2020)
- ii. TSC will also host Time Data Processing Unit(TDPU). In general, TDPU will consist of the following components:
 - Primary Reference Clock (PRC) as per the GR (TEC 49170:2020). PRC will provide the hold-over mechanism in case input references fail or become unavailable or spurious.
 - Data Processing Server
 - Time Signal Generator

- Frequency Synthesizer
 - Time Interval Counter
 - Optical Modem
 - TWSTFT Modem
 - GNSS Receiver
 - Management Console
- iii. Configuration and technical details of TDPU's components would be finalized by Deployment Committee in consultation with CSIR-NPL and ISRO. Installation of the specific component would be decided by the Deployment Committee as it depends on the kind of connectivity set up with NPL.

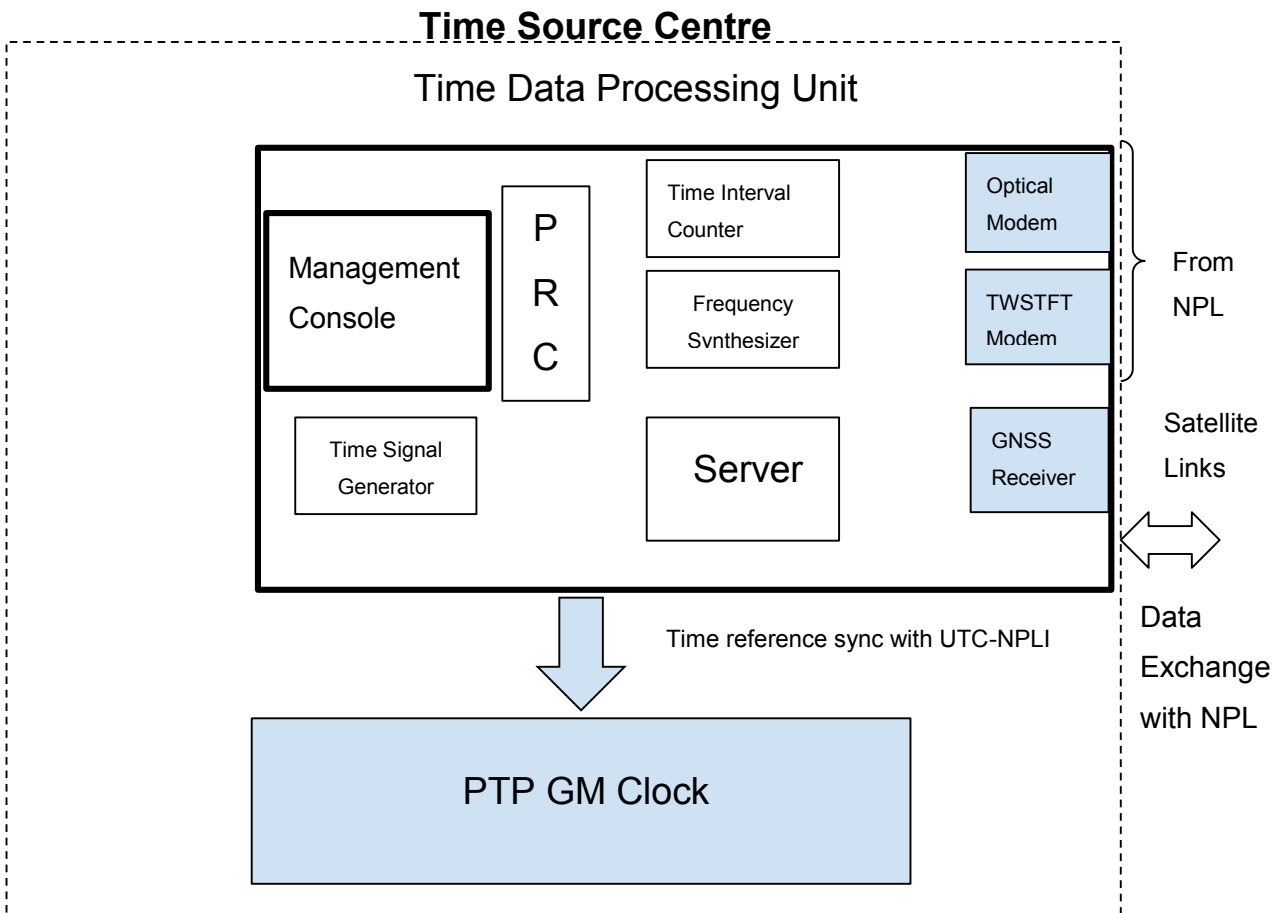

- iv. TSC would generally have the following input time references
 - a. From CSIR-NPL
 - b. From another TSC / RRSL
 - c. From NavIC.
- v. Department of Telecommunications signed an MoU with CSIR-NPL to extend reference clocks at LSA level. Modalities to receive Time reference from CSIR-NPL to Time Source Centres would be finalized by DoT.
- vi. Legal Metrological Unit under Department of Consumer Affairs with the help of ISRO and CSIR-NPL is setting up Regional Reference Standard laboratory (RRSL) to distribute UTC(NPLI) at Ahmedabad, Faridabad, Bhubaneswar, Guwahati and Bengaluru. It is envisaged that TSC would use the time reference from RRSL as a secondary source for their TSC wherever suitable. Necessary modalities and arrangements would be finalized by DoT.
- vii. The Department of Telecommunications will have an arrangement with ISRO to access high-quality time reference signals through GNSS NavIC services for TSCs.
- viii. NavIC is a dual band service with signals in L & S bands. A NavIC timing receiver shall support both of these bands.
- ix. PTP will compare the quality of input references and select the best one as per the approved plan.
- x. These Time Centres would provide necessary interfaces to LSPs to take reference timing information for their network as per the GR (TEC 49170:2020)
- xi. Time Source Centres would augment interfaces and capacity as per the requirement.
- xii. LSPs would set up a transmission medium up to the Time Source Centre for fetching timing information as per the technical specifications prescribed by the Time source Centre.
- xiii. Small ISPs may draw the time reference from the nearby NTP source of other LSPs to maintain uniformity of Time reference, as per the mandate of DoT.

- xiv. The tentative List of Equipment at each Time Source Centre is below, this would be duly updated after the Trial Phase :

Sl. No.	Equipment Type	TEC Standards
1	Primary Reference Clock (PRC)	TEC 49150:2019
2	PTP GM Clock	TEC 49170:2020
3	Switch	TEC 48060:2014
4	Firewall	TEC 49090:2014
5	Router	TEC 48050:2022

B. Dissemination of Time Reference from CSIR-NPL to TSCs

Time Source Centre would have input time reference signal from CSIR-NPL. There are the following ways to carry the time reference from CSIR-NPL to TSCs. The Deployment Committee may choose a suitable way to connect with a specific TSC.

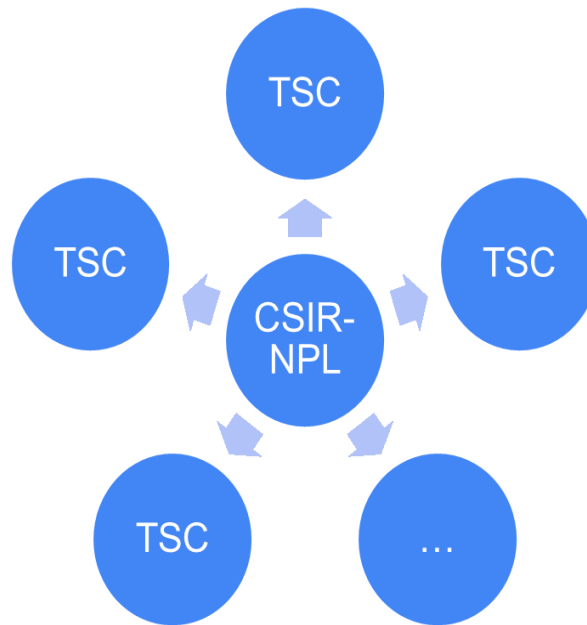

I. Two-way Satellite Time and Frequency Transfer (TWSTFT):

The TWSTFT technique utilizes a telecommunications geostationary satellite to compare clocks located in two different positions, i.e., at receiving and emitting stations. Two-way observations are scheduled between pairs of laboratories so that their clocks are simultaneously compared at both ends of the baseline using the satellite's transponder.

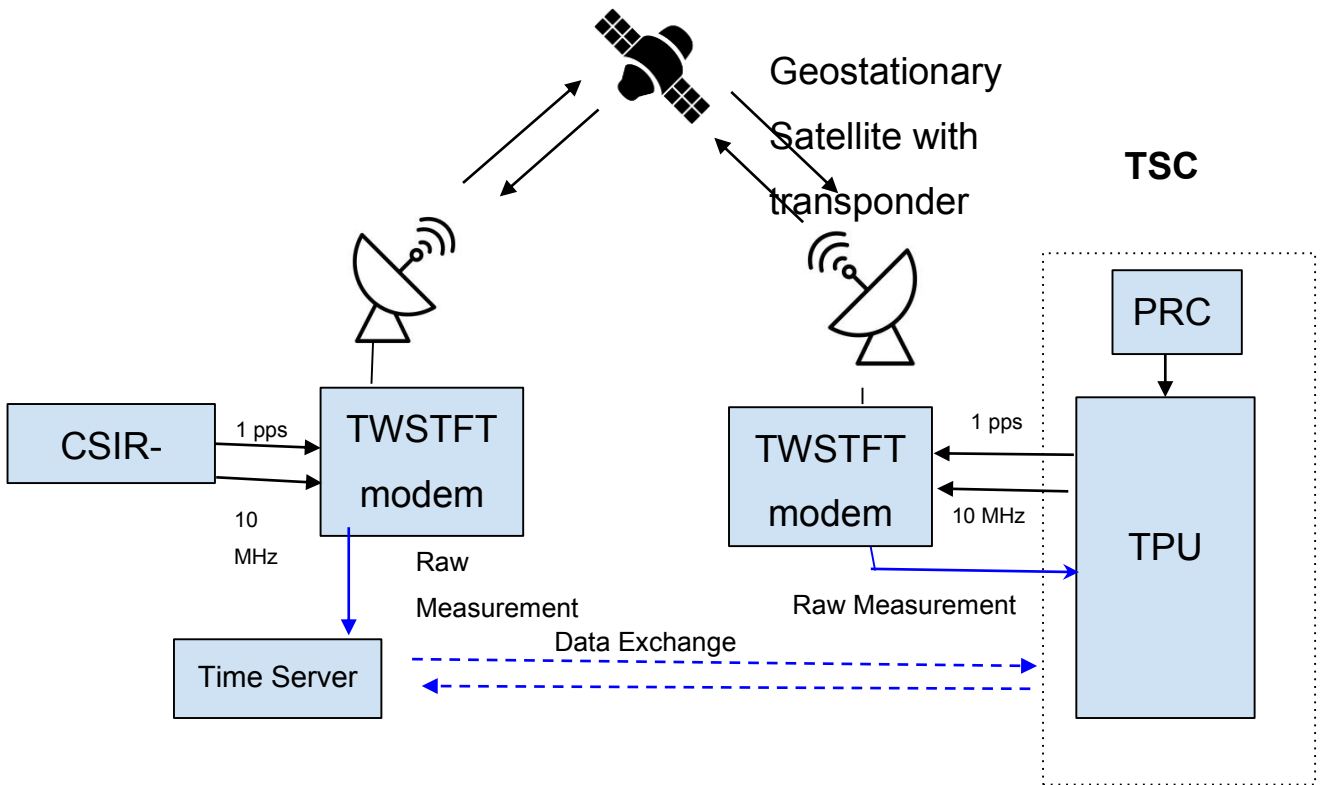

II. Carrying UTC(NPLI) through Optical Connectivity:

a. CSIR-NPL Primary Clock Site and TSC are co-located :

In case of CSIR-NPL Primary Clock Site and TSC are collocated then the input reference from CSIR-NPL will be directly provided to Time Source Centre (TSC) with optical connectivity/Electrical Connectivity. The deployment Committee in consultation with CSIR-NPL would select a suitable interface and connectivity and would further decide about the corresponding equipment required at TSC.

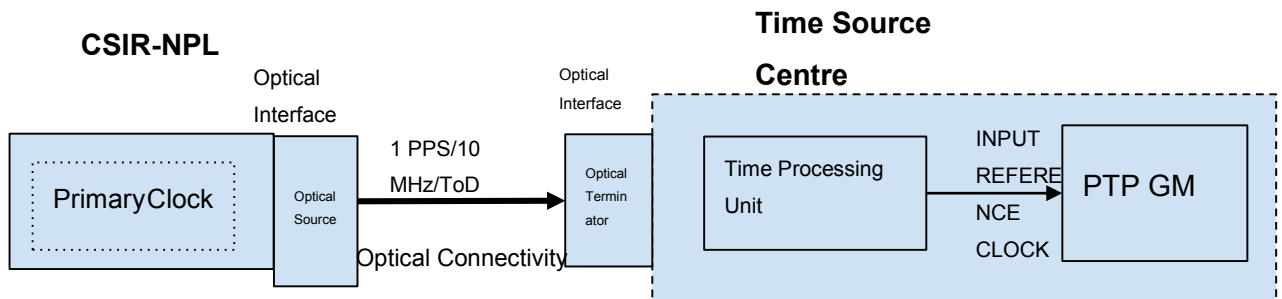

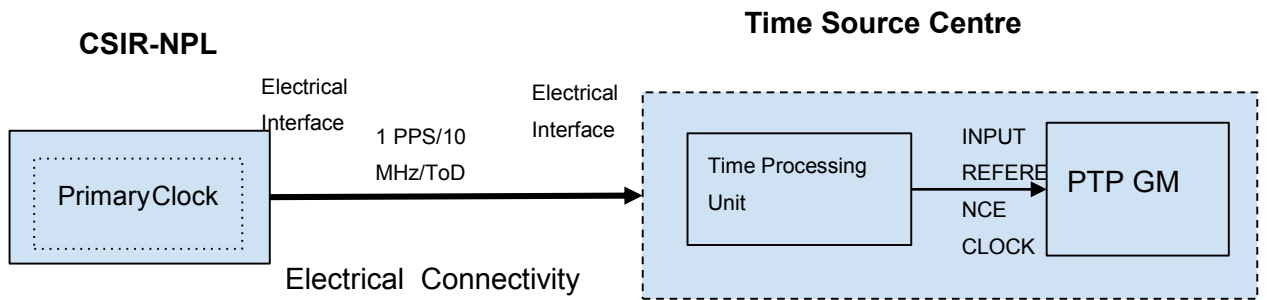

b. CSIR-NPL Primary Clock Site and TSC are not co-located

For non-located sites, the time reference is carried over dark fibre using BiDi SFPs and over fibre using DWDM. BiDi SFPs use a single mode single fibre to carry the time reference information. BiDi SFPs use two adjacent WDM wavelengths for Tx and Rx over a single fibre.

The deployment Committee in consultation with CSIR-NPL would select a suitable interface and connectivity and would further decide about the corresponding equipment required at TSC.

i. Bi-Di SFP over single fibre (Dark Fibre)

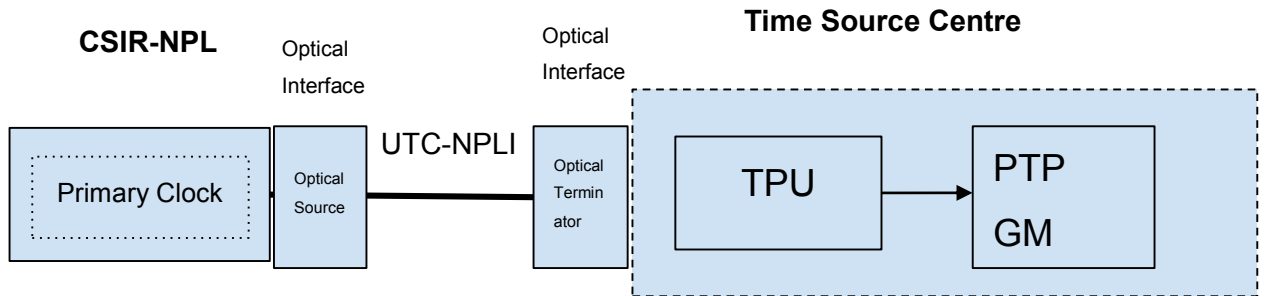

Dark Fiber using BiDi SFP

ii. Using OTC over DWDM

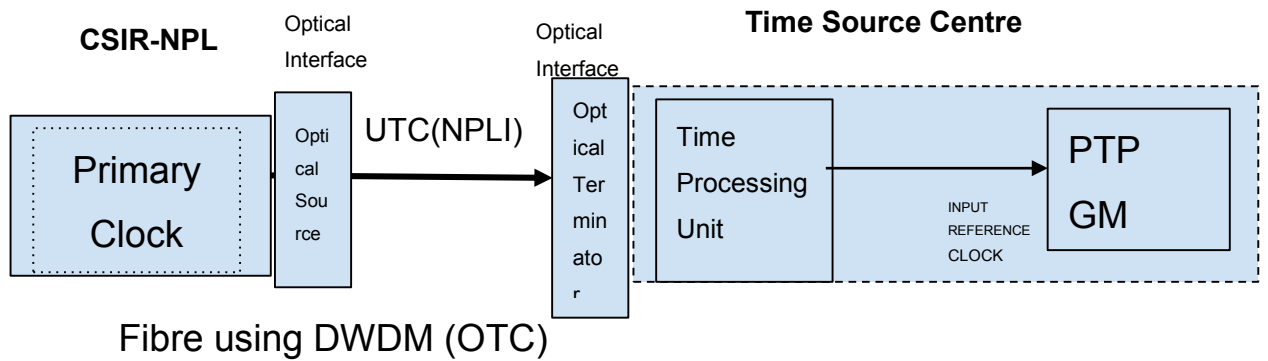

III. Common View of Global Navigational Satellite System (CVGNSS)

The CVGNSS method is another way to transfer time from CSIR-NPL site to TSC by comparing the clocks of CSIR-NPL PRC and TSC-PRC. The time signal embedded in a GNSS signal is the most commonly used source of common-view clock because of its wide visibility, ease of reception with good signal to noise ratio and insensitivity to propagation effects. CVGNSS time transfer is a one-way method, the signal being emitted by a satellite and received by specific equipment at the sites. However, the data is to be exchanged between TSC and CSIR-NPL to sync the clock of TSC with the clock of CSIR-NPL with good accuracy.

The deployment Committee in consultation with CSIR-NPL would select a suitable interface and connectivity and would further decide about the corresponding equipment required at TSC.

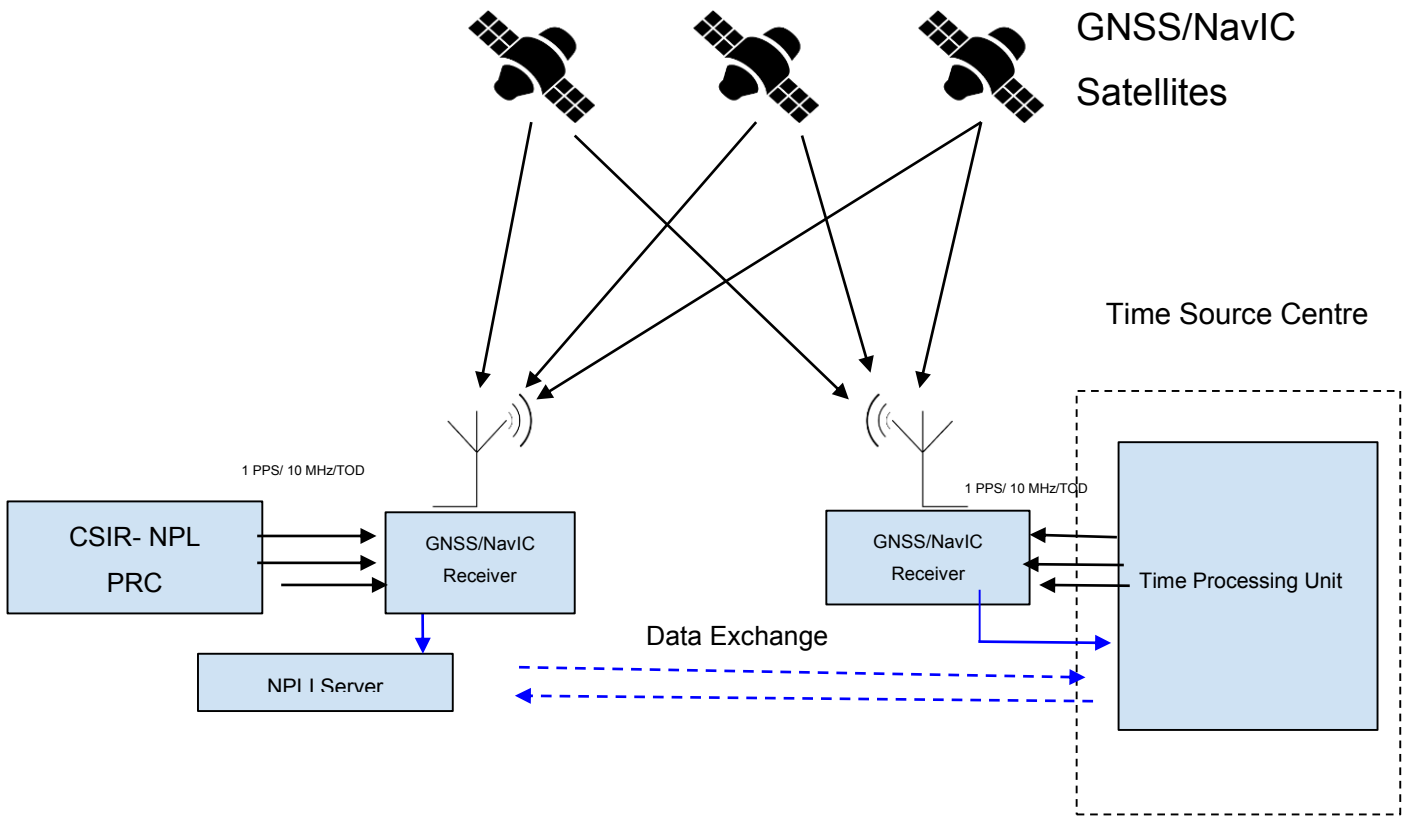

IV. Using Indian Navigational Satellite System (NavIC)

UTC(NPLI) time reference is embedded in the navigation signal which is broadcast by the NavIC satellite and received by NavIC receiver at Time Source Centre. This service is provided by ISRO.

The deployment Committee in consultation with ISRO would further decide about the configuration and details of corresponding equipment required at TSC.

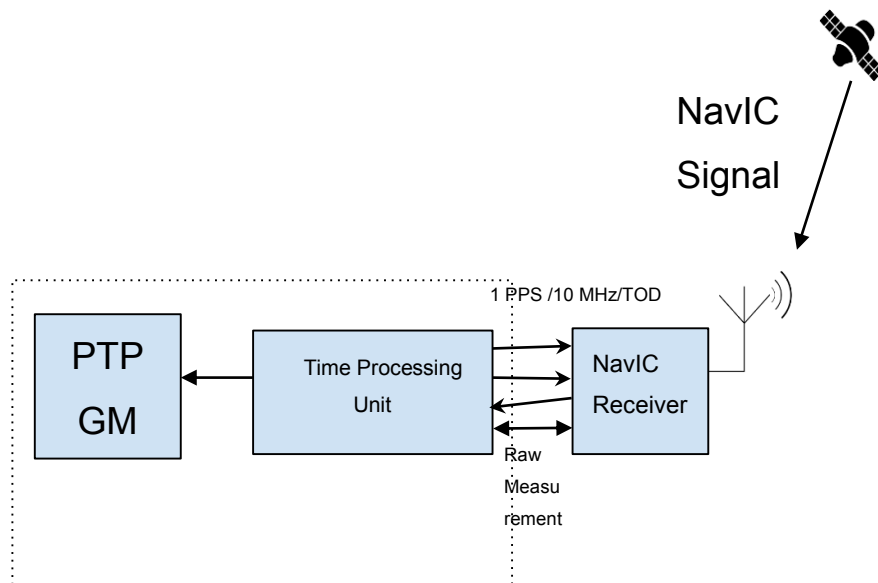

C. Management of TSCs

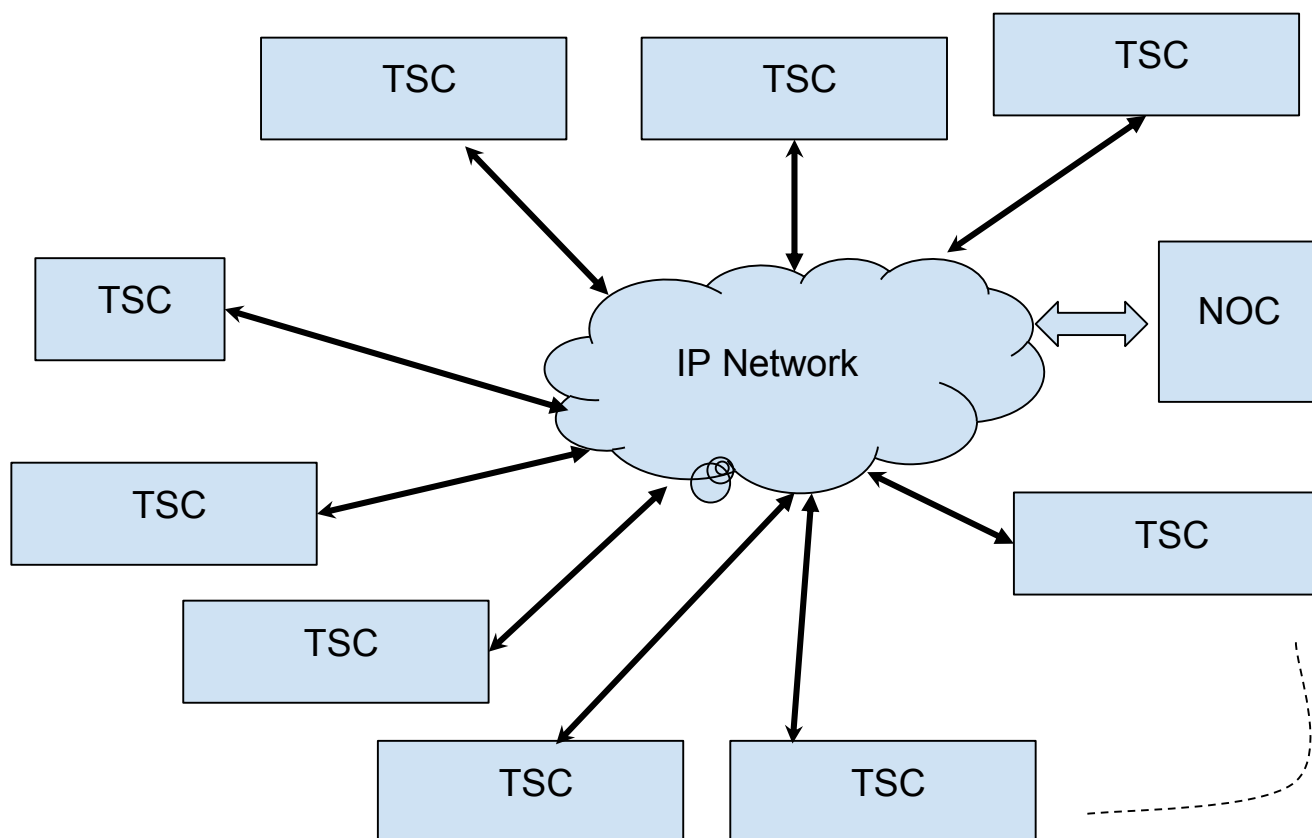

- i) Network Operations Centre (NOC) will be set up in Delhi.
- ii) The TSC shall support a fully managed Synchronization architecture providing full FCAPS for all the levels of manageability viz. fault, configuration, accounting, performance and security management, through a centralized location as per TEC eMS standard no (TEC 52006:2016).
- iii) NOC will monitor the health of TSC and also have the capability to manage the provision of access to a time reference.
- iv) NOC would keep a log of access provided for different LSP. It would produce customized reports as per the requirement.

D. Distribution of Time Reference Signal from TSC to LSP

I. Distribution of Time Reference Signal Using PTP protocol

- i) LSP shall set up Precision Time Protocol (PTP) Border Clock (BC) as per the GR (TEC 49170:2020). It will take the input clock reference from Time Source Centre.
- ii) LSP shall set up Precision Time Protocol (PTP) Slave Clock as per GR (TEC 49070:2012) for receiving time reference signal from TSC to its Network.
- iii) LSP may set up no. of Transparent Clocks (TC) in addition to Border clock and Slave Clock as per the requirement of the network and applications.
- iv) LSP may set up PTP link till the Packet gateway to synchronize their control plane.
- v) LSP shall be responsible for the transmission of Time Reference Signal from Time Source Centre to Border Clock and then to PTP Slave Clocks.
- vi) LSP shall synchronize all network elements of their network only with the time reference signal from TSC
- vii) All Timing servers must be within the national boundary of India.

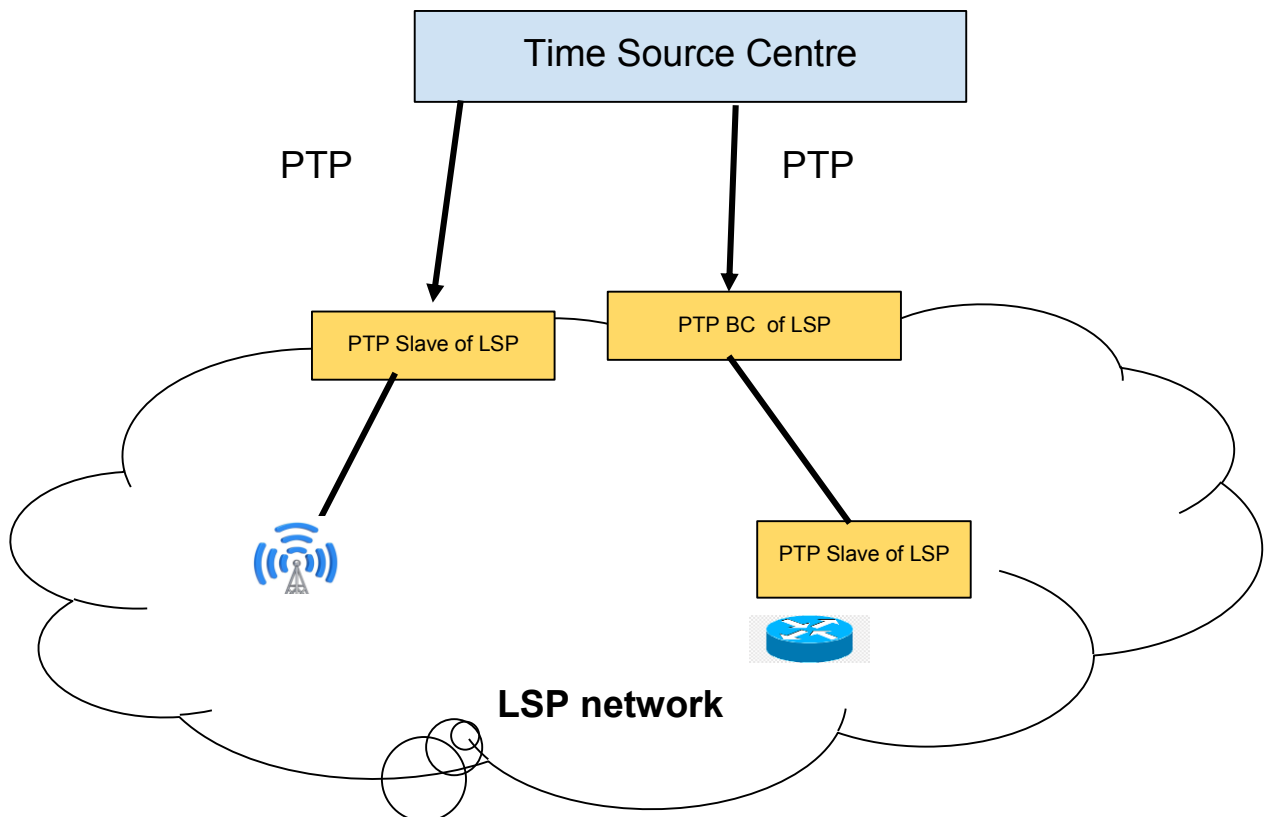

II. Distribution of Time Reference Signal Using NTP protocol

- i. Network Time Protocol (NTP) out of TSC would be Stratum 1. LSP may set up NTP Server Stratum 2 as per GR (TEC 48150:2019) and take NTP Out from TSC as an input time reference signal.

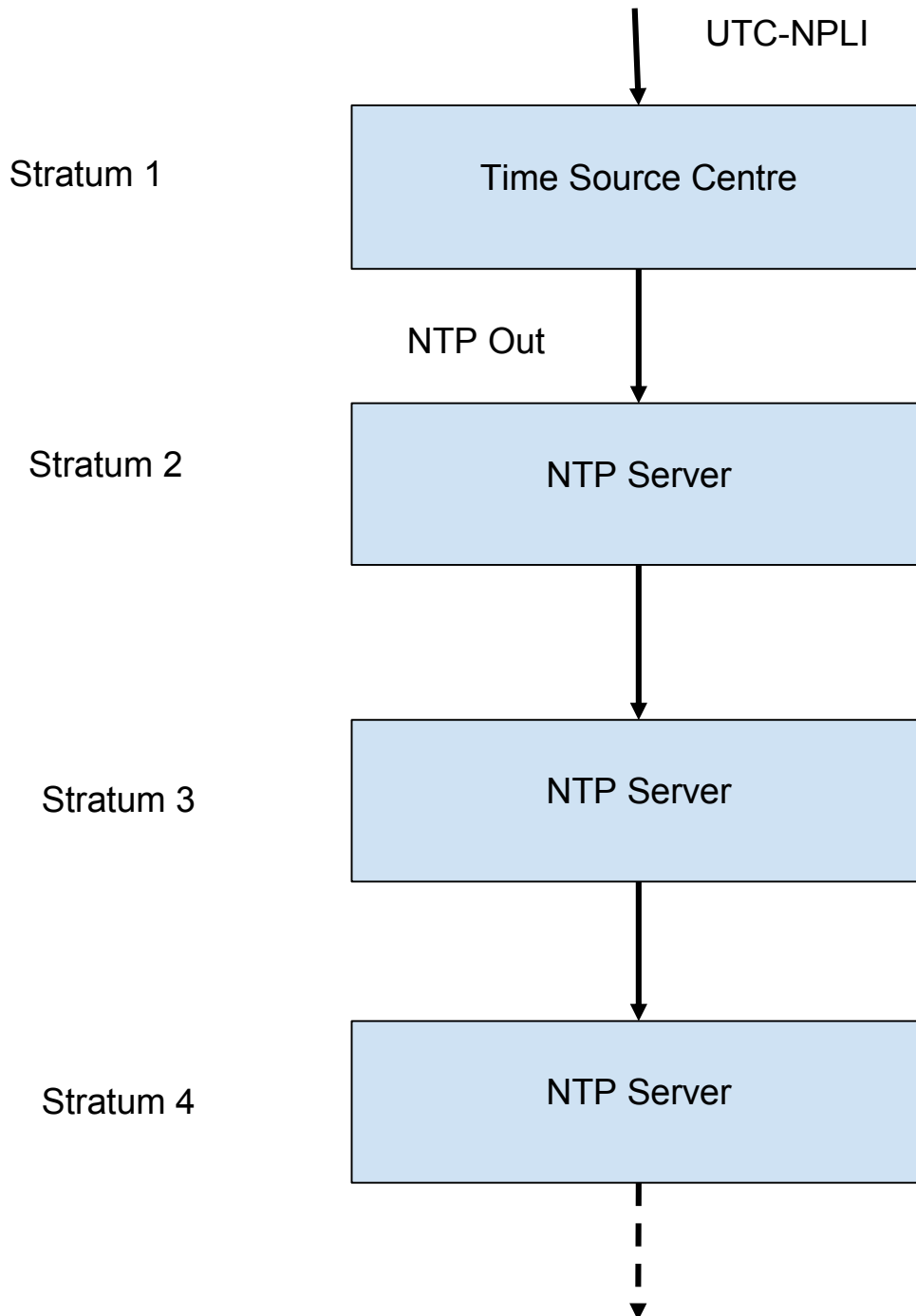

- ii. Similarly, LSP may set up NTP Stratum 3 as per GR (TEC 48150:2019) and take

a clock reference from NTP Stratum 2 which is in sync with NTP-Out of TSC.
So on and so for.

- iii. LSP shall synchronize all network elements of their network with the closest NTP servers.
- iv. ISP will connect to the types of NTP servers depending on their requirements.

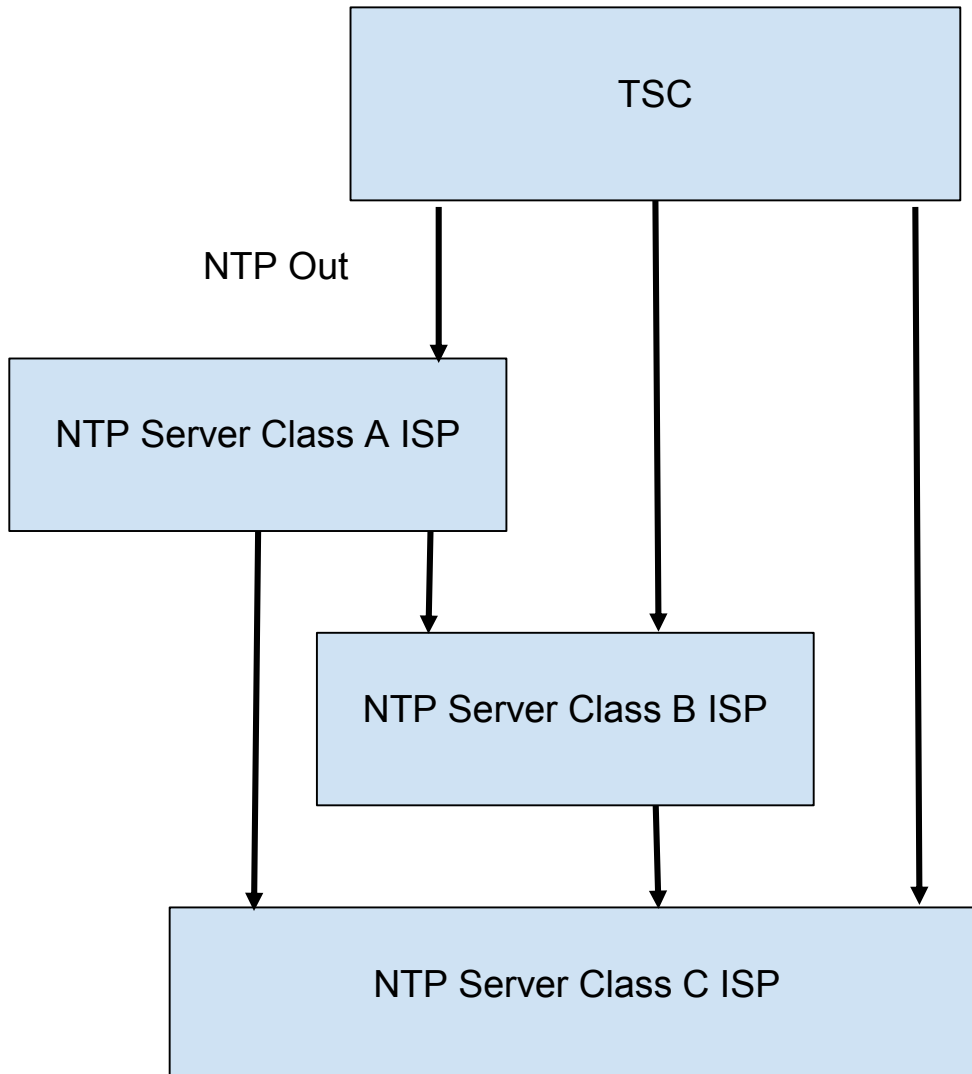

- v. If the telecom services are retailed to other entities then LSP will ensure that the time reference of all network elements of the outsourced network would be traced back to UTC(NPLI).

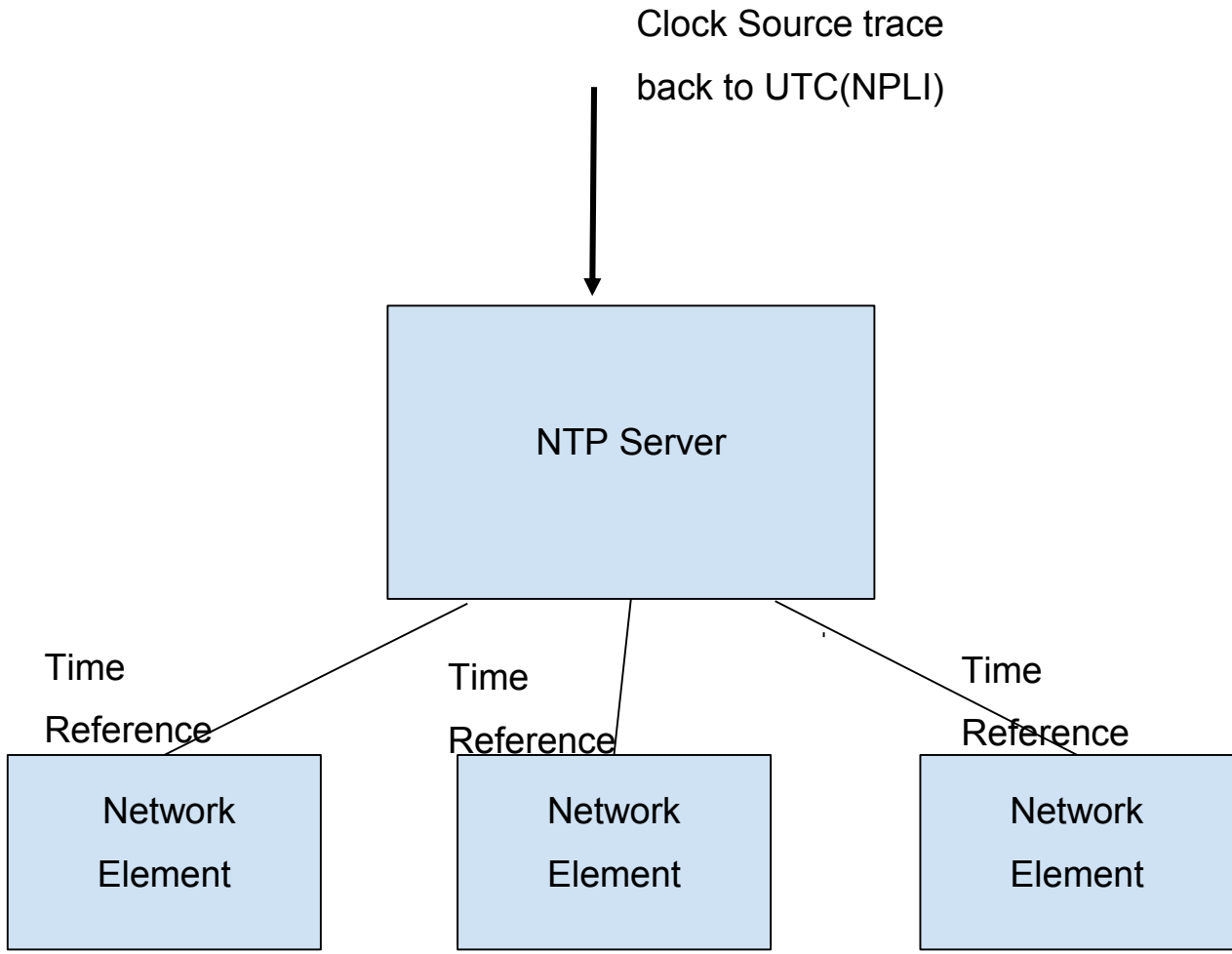

- vi. Users (NTP Clients) can also access Standard NTP output time reference signal through the public Internet.

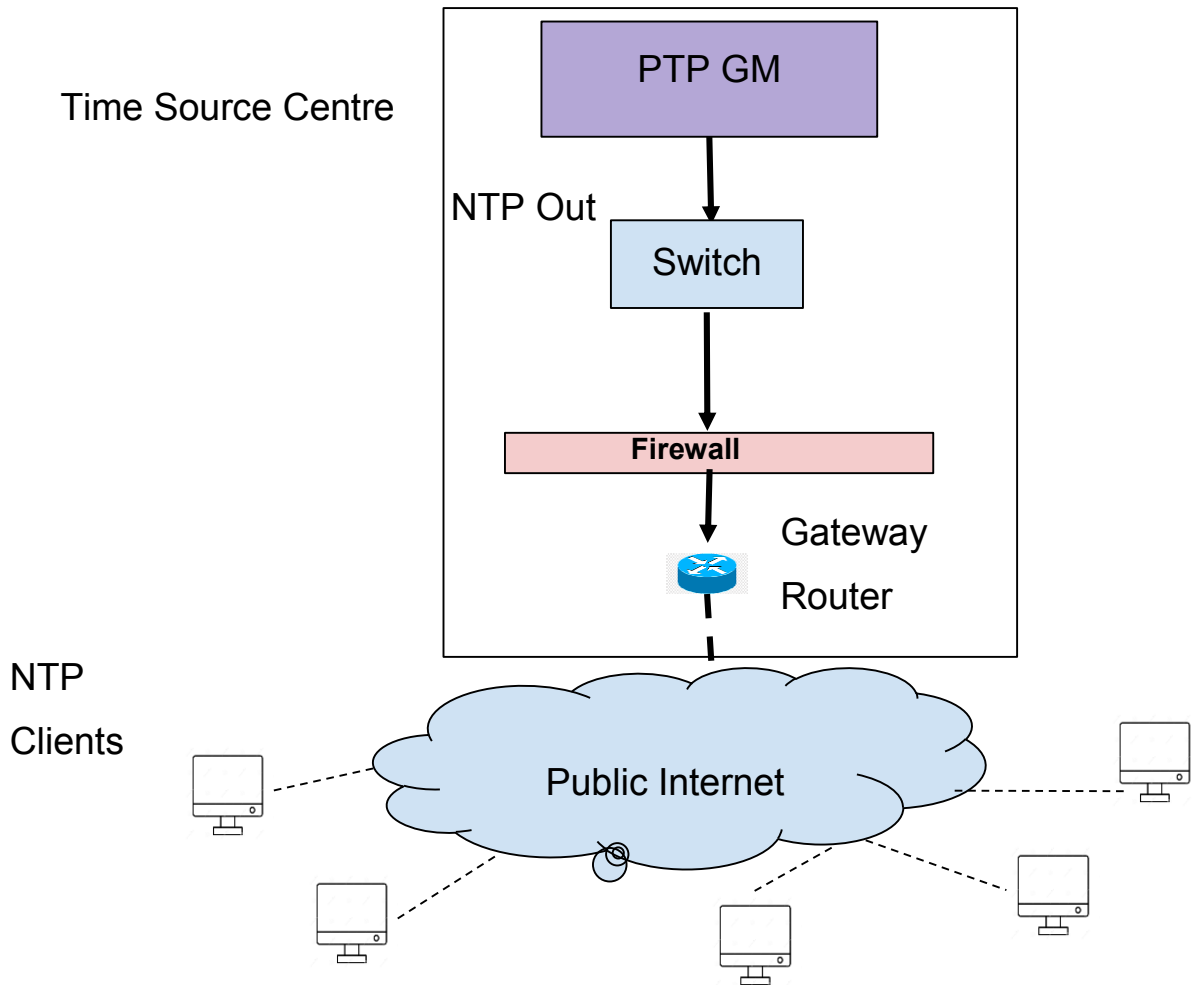

vii.

III. Accessing Indian Standard Time Reference Signal through NavIC

LSP may use NavIC receiver to receive a time reference signal from NavIC at as many places as it may require. However, they need to have a mechanism to verify that timing information is correctly synced with the UTC(NPLI). If timing information could not be synced due to a technical fault, then the provision of an alternate source (i. e. terrestrial based time reference) should be available for synchronization.

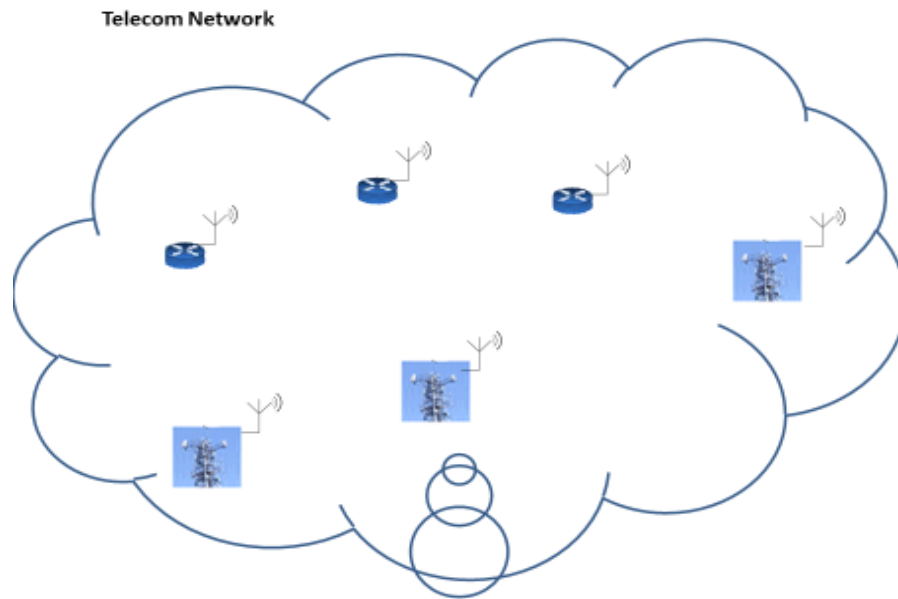

IV. Distribution of Time Reference Signal Using Using E1 interface

Time reference can be distributed to TDM Network Element of LSP by connecting E1 out from TSC device to a suitable network element of LSP network.

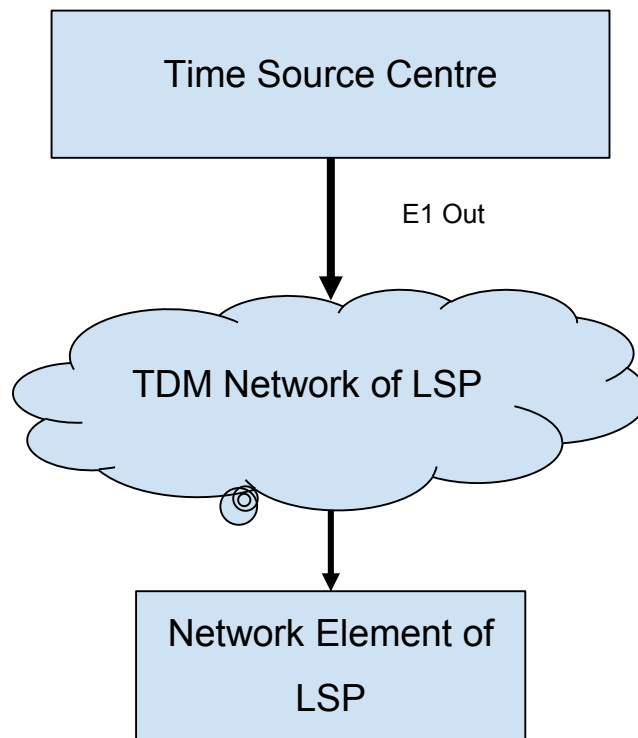

V. Distribution of Time Reference Signal Using SyncE

Time reference can be distributed to the Synchronous Ethernet network of LSP by connecting SyncE out the interface of TSC to Ethernet Switch supporting Synchronous Ethernet of LSP.

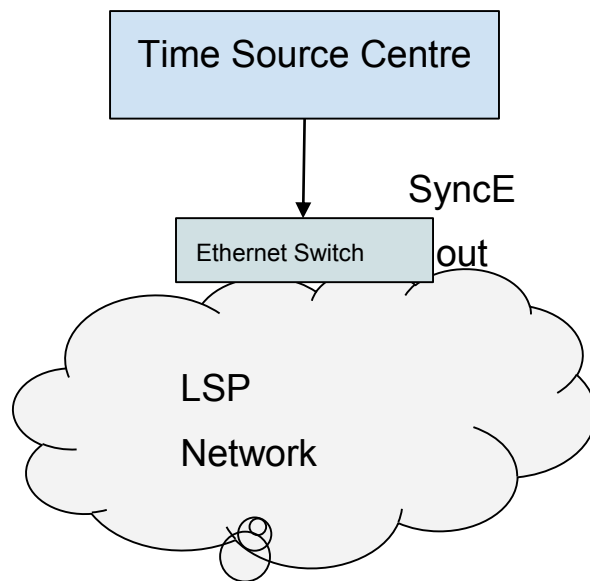

4. Deployment Plan

A. General Guidelines

- I. Licensed Service providers shall not use public Timing Sources. They shall only use UTC(NPLI) time reference provided by CSIR-NPL, the official timekeeper of the Nation.
- II. UTC(NPLI) time reference is available at Time Source Centres established by the Department of Telecommunications. Time reference signal shall provide frequency, phase and TOD synchronization requirements for the LSP.
- III. Time reference Signal in TSC is available on PTP, NTP, PPS, SyncE and TDM interfaces as per GR (TEC 49170:2020). UTC(NPLI) may also be received through satellite navigation signal NavIC provided by ISRO. The priorities shall be set in the TSC for the selection of the input reference clock. PTP GM at TSC has suitable built-in algorithms to check the accuracy of the incoming clock and in case of any deviations beyond 1pps, it automatically switches over to the next priority clock.
- IV. LSP has to set up their own dedicated and secure link to receive the Time reference signals from TSC.
- V. Before mandating LSP to switch to NavIC time reference, the availability of GNSS antenna/receiver in the compatible frequency band for NavIC has to be looked into.
- VI. Time reference clock of all network elements of LSP must trace back to UTC(NPLI).
- VII. LSP would establish communication links with TSC as described above.
- VIII. Timing servers of LSPs shall be isolated from the Public Internet.
- IX. In case LSP uses PTP out time reference signal from TSC, either the LSP may set PTP slave to use TSC as the PTP Grandmaster or the LSP may configure its PTP Grandmaster as a Boundary clock having input reference clock from PTP out of TSC.
- X. Public NTP servers shall not be used by Licensed service providers.
- XI. NTP out of TSC is Stratum 1. Class A ISP shall set up NTP Server as per TEC GR (TEC 48150:2019) as Stratum 2. Time reference signal can further

be redistributed into its own network elements as well as to Class B ISP. Another NTP Server (i.e Stratum 3) may be set up having input time reference from Stratum 2. All NTP servers of LSP must trace back its clock reference to UTC(NPLI).

- XII. The various logs maintained by Licensed service providers using NTP Server should have a time resolution of 1 second. Therefore, service providers shall achieve time accuracy within UTC NPLI +/-0.5 second in the network.
- XIII. LSP shall seek to minimize the network delay by bringing the stratum-2 time references as close to the network elements as possible.
- XIV. The Physical connectivity over the GE optical interface at TSC to the LSP Router provides the SyncE clock to the LSP network with accuracy as per G.8261 and G.8262 standards. This method is similar to clock synchronization in SDH networks.
- XV. The LSP's retailers may configure their Servers and computers to access NTP out Time reference signal from TSC through public internet using URL. The Server URL, as well as the IP address, shall be published for use by the LSP and their clients.
- XVI. Maintenance of TSC/NOC/associated network would be outsourced either to OEM or to a consortium led by OEM.
- XVII. TEC would update GR on Precision Time Protocol (PTP) Grandmaster Clock - (TEC 49170:2020), Precision Time Protocol (PTP) Slave Clock - (TEC 49070:2012), Network Timing Protocol Server - (TEC 48150:2019) and any other relevant GR periodically in consultation with the stakeholders.
- XVIII. Department of Telecommunications shall notify LSP regarding the availability of TSC at various locations and modalities to access time reference signals from TSC separately.
- XIX. Deployment Committee may make the provision to provide time reference from TSC to other government organisations with the approval of the competent authority.
- XX. After the successful implementation of the plan, Department of Telecom may amend licensing conditions to make it mandatory for licensees to use the time reference that can be traced back to UTC(NPLI).

B. Security and Reliability Guidelines

- I. TSC should be fully redundant to avoid any single point of failure.
- II. Clock Module Redundancy: PTP GM of TSC shall comprise of Rubidium Atomic Clock Oscillator module (Main) and Oven Controlled Crystal Oscillator(OCXO) module (Backup).
- III. Each TSC would have input UTC(NPLI) time reference from CSIR NPL (Primary) and another TSC/RRSL (secondary) for redundancy.
- IV. TSC is planned to have input time references from CSIR-NPL, GNSS/NavIC time reference through a satellite link.
- V. Equipment should have hot-swappable dual power supply units.
- VI. TSC should use equipment from Trusted Sources as per National Security Directive on Telecommunication(NSDTS).
- VII. For the stable and error-free operation of the PRC, it is recommended to keep the unit in a quiet place with the following conditions.
 - a. Temperature should be relatively stable
 - b. No powerful electrical engine around
 - c. DC power supply stable and relatively noiseless
 - d. No powerful vibrations source

VIII. Vulnerability of GNSS and Need for Terrestrial based Time Distribution

GNSS has been widely used in communication infrastructures to provide precise time. The wide use of GNSS comes with many threats, including jamming, spoofing and interference from other sources operating in the adjacent band to the GNSS band. GNSS Jamming is a deliberate attempt to disrupt NavIC services.

- a. GNSS spoofing is an attack on the system, where a valid GNSS signal is transmitted with altered position and time of day content. If the counterfeit signal strength is stronger than the actual valid GNSS signal, the receiver could decode the wrong time and location information. Spoofing of GNSS signals can be handled using anti-spoofing techniques.
 - ❖ It is recommended that the LSPs employ anti-spoofing and anti-jamming techniques in NavIC receivers.
- b. The time-distribution system should have reliability, availability, robustness, and security, including cybersecurity and malicious attacks on GNSS. The best

way to avoid such attacks and ensure that GNSS does not become a single point of failure is to use terrestrial-based time distribution. As the criticality of precise time-based applications increases, so do the requirements for time-distribution system reliability.

- ❖ It is recommended that LSPs also have terrestrial based time distribution in addition to NavIC time reference signal.
- IX. All Timing servers of LSP must be within the national boundary of India.
- X. Energy requirements of TSC must be available 24x7 with an adequate alternate power source and backup.
- XI. Physical and cybersecurity of TSC and NOC must be ensured as deemed fit for critical infrastructure.
- XII. LSPs must document and maintain their synchronization procedures for Clocks. They must keep a log of the times when they synchronize their Clocks and the results of the synchronization process. This log should include notice of any time a Clock drifts more than the applicable tolerance specified. Such a log must be kept for a period of five years.

C. Trial Phase and Proof of Concept

- I. Time Source Centres would be established first in Delhi followed by at Mumbai and Prayagraj.
 - i. TSC at Delhi would have connectivity from CSIR-NPL on PTP connectivity on fibre and secondary connectivity from RRSL Faridabad (if feasible).
 - ii. TSC at Mumbai would have connectivity through *Common View of Global Navigational Satellite System (CVGNSS)* from CSIR NPL.
 - iii. TSC at Prayagraj would have connectivity on long-haul connectivity on fibre with CSIR-NPL and secondary connectivity from the nearest RRSL (if feasible). This TSC would be without the PRC.
 - iv. The trial phase would assess whether TSC and NavIC would be able to deliver the time reference to control as well as data plan of LSPs with desired quality.
 - v. Continuous feedback from LEAs on improvement in the analysis of network logs would be taken.

- vi. Learnings of the Trial phase would be incorporated to devise the next phase of the plan in consultation with the stakeholders.

D. First phase of Implementation

- i. The Deployment plan may suitably be reviewed and revised based on the learning and feedback of the trial Phase and in consultation with the stakeholders.
- ii. NOC to manage TSCs would be set up in Delhi.
- iii. Deployment Committee may decide about having PRC at TSC sites on the basis of connectivity with NPL and requirements at a specific site. It is not envisaged to have PRC at all sites of TSC. The mode of connectivity with CSIR-NPL would be decided on a case-to-case basis by Deployment Committee. It may change the venue of TSC if requires and recommend more sites for the next phase.
- iv. After a successful trial and Proof of Concept, TSC would be rolled out at the following places:

SNo.	State	Place of TSC	States Covered
1	Andhra Pradesh	Hyderabad	Andhra Pradesh and Telangana
2	Mizoram	Aizawl	All NE States
3	Bihar	Patna	Bihar
4	Chhattisgarh	Raipur	Chhattisgarh
5	Jharkhand	Ranchi	Jharkhand
6	Gujarat	Junagarh	Gujarat, Daman & Diu, Nagara
7	Haryana	Ambala	Haryana
8	Himachal Pradesh	Shimla	Himachal Pradesh

9	Jammu & Kashmir	Jammu	J&K and Laddakh
10	Karnataka	Bijapur	Karnataka
11	Kerala	Ernakulam	Kerala
12	Madhya Pradesh	Bhopal	Madhya Pradesh and Chhattisgarh
13	Maharashtra	Goa	Maharashtra and Goa
14	Odisha	Koraput	Odisha
15	Punjab	Jalandhar	Punjab Chandigarh and
16	Rajasthan	Jaipur	Rajasthan
17	TamilNadu	Chennai	Tamilnadu
18	UP(East)	Prayag Raj	UP(East)
19	UP(West)	Dehradun	UP(West) Uttarakhand and
20	West Bengal	Kolkata	West Bengal

E. Final Phase of Implementation

- i. The Deployment plan may suitably be reviewed and revised based on the learning and feedback of the first Phase and in consultation with the stakeholders.
- ii. LSP can receive UTC(NPLI) through NavIC. It largely serves the purpose of LSPs. As the Telecom network is a critical infrastructure, it may not be left with a single time-reference source as GNSS may be prone to spoofing and hacking. In order to provide a time reference signal through terrestrial means, TSC has to be established at such granularity to provide a quality time reference signal at the bottom of the network.
- iii. So TSC may be established at around 80 locations including what is already set up at the previous implementation phases as shown on the grid in the map below. However, the requirement to expand the network of TSC would be reassessed based on feedback/learning of implementation of the First Phase.

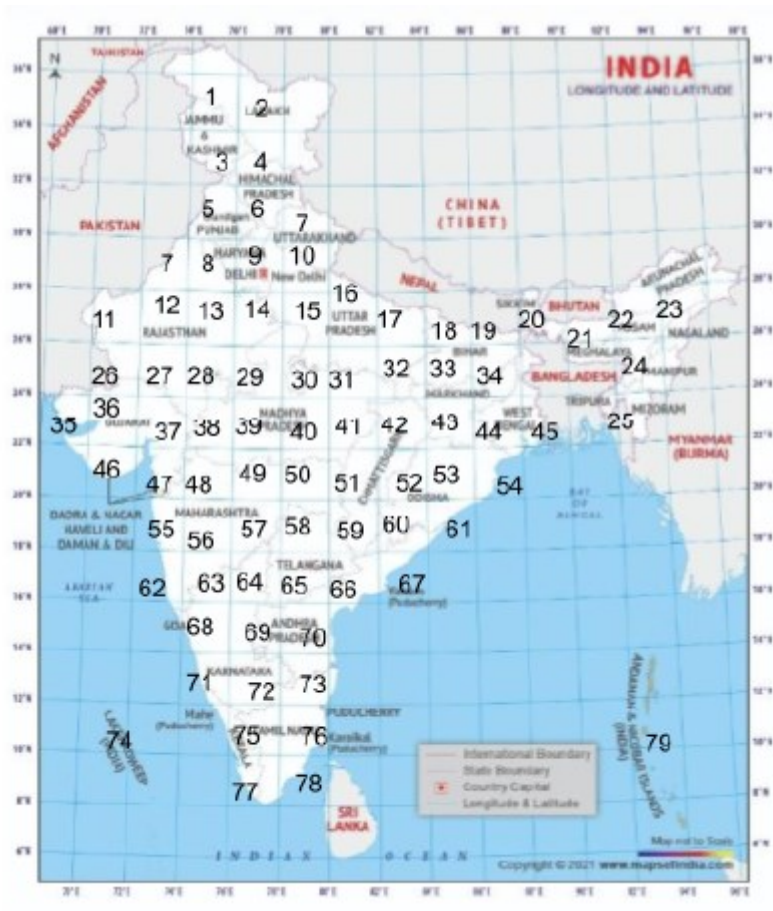

F. Constitution of Deployment Committee

- i. Deployment Committee shall be constituted under the Chairmanship of an officer of the rank of DDG under the office of DG(Telecom) for the implementation and operation of the Deployment Plan during the trial and proof of Concept Phase.
- ii. Thereafter, the special cell may be created under DG (Telecom) to operate and maintain TSC and manage the provisioning of LSP for accessing Time Reference signal at TSC. Secretariat with adequate staff would be created for office record keeping and supervision.
- iii. Department of Telecommunications may create a Special Purpose Vehicle (SPV) for professionally managing Time Reference Signal Distribution activities with a guaranteed Service Level Agreement (SLA) to LSPs. After the final phase of implementation, time reference signals may be provided to LSP within 200 Km of its network elements. At this stage, revenue generation from LSP may be explored as LSP would not require to invest in time synchronization network for their network operation.
- iv. Deployment Committee would frame the rules for certification and audit of the compliance by LSP.
- v. Deployment committee may ask licensees to provide the status of Synchronization at any time.
- vi. LSPs shall share the report in the format specified by the Deployment Committee periodically.
- vii. Each licensee must report to the Deployment Committee any abnormality regarding Clock health.

Abbreviations

<i>AAA</i>	<i>Authentication Authorization and Accounting</i>
<i>ATM</i>	<i>Asynchronous Transfer Mode</i>
<i>CDR</i>	<i>Call Detail Record</i>
<i>CSIR</i>	<i>Council of Scientific and Industrial Research</i>
<i>CVGNSS</i>	<i>Common View of Global Navigational Satellite System</i>
<i>DoT</i>	<i>Department of Telecommunications</i>
<i>DWDM</i>	<i>Dense wavelength-division multiplexing</i>
<i>FDD</i>	<i>Frequency Division Duplex</i>
<i>FDMA</i>	<i>Frequency Division Multiple Access</i>
<i>GGSN</i>	<i>Gateway GPRS Support Node</i>
<i>GPRS</i>	<i>General Packet Radio Service</i>
<i>GPS</i>	<i>Global Positioning System</i>
<i>GSM</i>	<i>Global Service Mobile</i>
<i>IETF</i>	<i>Internet Engineering TAsk Force</i>

<i>IP</i>	<i>Internet Protocol</i>
<i>ISP</i>	<i>Internet Service Provider</i>
<i>ISRO</i>	<i>Indian Space Research Organisation</i>
<i>LSP</i>	<i>Licensed Service Provider</i>
<i>LTE</i>	<i>Long Term Evolution</i>
<i>MPLS</i>	<i>Multi-protocol Label Switching</i>
<i>MSC</i>	<i>Mobile Switching Centre</i>
<i>NAT</i>	<i>Network Address Translation</i>
<i>NavIC</i>	<i>Navigation with Indian Constellation</i>
<i>NPL</i>	<i>National Physical Laboratory</i>
<i>NPLI</i>	<i>National Physical Laboratory India</i>
<i>NTP</i>	<i>Network Time Protocol</i>
<i>PDH</i>	<i>Plesiochronous Digital Hierarchy</i>
<i>PRC</i>	<i>Primary Reference Clock</i>
<i>PDSN</i>	<i>Packet Data Serving Node</i>
<i>PNT</i>	<i>Positing Navigation & Timing</i>

<i>PON</i>	<i>Passive Optical Network</i>
<i>PTN</i>	<i>Packet Transport Network</i>
<i>PTP</i>	<i>Precision Time Protocol</i>
<i>RFC</i>	<i>Request for Comments</i>
<i>RRSL</i>	<i>Regional Reference Standard Laboratory</i>
<i>SDH</i>	<i>Synchronous Digital Hierarchy</i>
<i>SGSN</i>	<i>Serving GPRS Support Node</i>
<i>SLA</i>	<i>Service Level Agreement</i>
<i>SPV</i>	<i>Special Purpose Vehicle</i>
<i>SSU</i>	<i>Synchronous Supply Unit</i>
<i>SyncE</i>	<i>Synchronous Ethernet</i>
<i>TDD</i>	<i>Time Division Duplex</i>
<i>TDM</i>	<i>Time Division Multiplexing</i>
<i>TEC</i>	<i>Telecommunication Engineering Centre</i>
<i>TSC</i>	<i>Time Source Centre</i>
<i>TSP</i>	<i>Telecom Service Provider</i>

<i>TWSTFT</i>	<i>Two-way Satellite Time & Frequency Transfer</i>
<i>UDP</i>	<i>User Datagram Protocol</i>
<i>UMTS</i>	<i>Universal Mobile Telecommunications Service</i>
<i>UTC</i>	<i>Coordinated Universal Time</i>
<i>WAN</i>	<i>Wide Area Network</i>
<i>WCDMA</i>	<i>Wideband Code Division Multiple Access</i>
<i>3GPP</i>	<i>3rd Generation Partnership Project</i>



